

INSTRUCTIONS AND PARTS MANUAL

AGS-4000_(120VAC) AGS-4100_(240VAC) ARC GOUGING SYSTEM

Please record your equipment identification information below for future reference. This information can be found on your machine nameplate.

Model Number: _____

Serial Number: _____

Date of Purchase: _____

Whenever you request replacement parts or information on this equipment, always supply the information you have recorded above.

LIT-AGS-4000-IPM-0326

Bug-O Systems is committed to empowering our customers by providing operator controlled mechanized solutions for their welding, cutting and custom applications.



B U G - O S Y S T E M S

A DIVISION OF WELD TOOLING CORPORATION



280 TECHNOLOGY DRIVE CANONSBURG, PENNSYLVANIA 15317-9564 USA
PHONE: 412-331-1776 <https://www.bugo.com> FAX: 412-331-0383

SAFETY

PROTECT YOURSELF AND OTHERS FROM SERIOUS INJURY OR DEATH. KEEP CHILDREN AWAY. BE SURE THAT ALL INSTALLATION, OPERATION, MAINTENANCE AND REPAIR PROCEDURES ARE PERFORMED ONLY BY QUALIFIED INDIVIDUALS.



ELECTRIC SHOCK can kill.

- 1) The equipment is not waterproof. Using the unit in a wet environment may result in serious injury. Do not touch equipment when wet or standing in a wet location.
- 2) The unused connectors have power on them. Always keep the unused connectors covered with the supplied protective panels. Operation of the machine without the protective panels may result in injury.
- 3) Never open the equipment without first unplugging the power cord or serious injury may result.
- 4) Verify the customer-supplied power connections are made in accordance with all applicable local and national electrical safety codes. If none exist, use International Electric Code (IEC) 950.
- 5) Never remove or bypass the equipment power cord ground. Verify the equipment is grounded in accordance with all applicable local and national electrical safety codes. If none exist, use International Electric Code (IEC) 950.

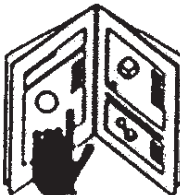

READ INSTRUCTIONS.

Read the instruction manual before installing and using the equipment.



EQUIPMENT DAMAGE POSSIBLE.

- 1) Do not plug in the power cord without first verifying the equipment is OFF and the cord input voltage is the same as required by the machine or serious damage may result.
- 2) Always verify both the pinion and wheels are fully engaged before applying power or equipment damage may occur.
- 3) Do not leave the equipment unattended.
- 4) Remove from the work site and store in a safe location when not in use.



FALLING EQUIPMENT can cause serious personal injury and equipment damage.

Faulty or careless user installation is possible. As a result, never stand or walk underneath equipment.



MOVING PARTS can cause serious injury.

- 1) Never try to stop the pinion from moving except by removing power or by using the STOP control.
- 2) Do not remove any protective panels, covers or guards and operate equipment.

HIGH FREQUENCY WARNINGS

SPECIAL PRECAUTIONS ARE REQUIRED WHEN USING PLASMA, TIG OR ANY WELDING PROCESS THAT USES HIGH FREQUENCY TO STRIKE AN ARC.



WARNING: HIGH FREQUENCY CAN EFFECT MACHINE OPERATION AND THEREFORE, WELD QUALITY.

Read the precautions below before installing and using the equipment.

PRECAUTIONS:

- 1) Some plasma or welding cables are strong sources of high frequency interference. NEVER lay a plasma or welding cable across the controls of the machine.
- 2) Always physically separate the plasma or welding cable leads from the machine cables. For example, the plasma or welding cable leads should NEVER be bundled with a pendant cable or the machine power cord. Maximize the separation between any machine cables and the plasma or welding cables.
- 3) Strictly follow the grounding procedures specified for the plasma or welding unit. NOTE: Some plasma and welding units produce exceptionally large amounts of high frequency noise. They may require a grounding rod be driven into the earth within six feet (2 meters) of the plasma or welding unit to become compatible with an automatic cutting or welding process.
- 4) If the high frequency is produced using a spark gap, adjust the points so the gap is as small as possible. The larger the gap, the higher the voltage and the higher the interference.
- 5) Some plasma or welding units will inject high frequency interference into the AC power line. Use separate power line branches whenever possible to power the plasma or welding source and the machine. Do not plug them into the same outlet box.
- 6) High frequency noise may enter the machine through the plasma or welding supply remote contactor leads. Some plasma and welding sources can produce noise spikes of up to several thousand volts. These sources are not compatible with automated cutting and welding equipment. It is recommended that the remote contactor leads on these plasma or welding sources not be connected to the machine. An alternate solution is to purchase a separate remote contactor isolation box.

AGS-4000 ARC GOUGING SYSTEM

INSTRUCTIONS AND PARTS MANUAL

TABLE OF CONTENTS

PAGE	
5	Introduction / Standard Features
6	Additional Features
7	Bug-O Technical Data / Dimensions
8	Arcair® N7500 Technical Data
9-11	System Configurations
9	System Configurations / Bug-O Kits With Arcair® Automatic Gouging System
9	System Configurations / AGS-4172 Arcair® N7500 Mounting Group
10	System Configurations / Bug-O Kits Without Arcair® Automatic Gouging System
11	System Configurations / Bug-O Supplied Arcair® N7500 Automatic Gouging System
11	System Configurations / Arcair® N7500 Automatic Gouging System Spare Parts
12-16	Setup
17	Arc Gouging Module
18	Digital Readout Calibration
19	AGS-4172 Arcair® Mounting Group / Exploded View / Parts List
20	MPD-1000 Master Drive Unit / Exploded View
21	MPD-1000 Master Drive Unit / Parts List
22	AC Power Wiring Diagram
23	Signal Wiring
24-27	ARR & AFR Rail, Mounting and Carriages Options
24	Aluminum Rigid Rail / Cross Section / Exploded View / Parts List
25	AFR-3000 Semi Flex Rail / Cross Section / Exploded View / Parts List
26	ARM-2010 / AFR-2010 On/Off Magnet Assembly
26	ARR & AFR Vacuum Assemblies
27	MPD-1065 Releasable Carriage / Exploded View / Parts List
28-29	BRR Rail, Mounting and Carriages Options
28	BRR-1180 Bent Rigid Rail / Cross Section / Application View / Parts List
28	Complete Ring Rail Assemblies
29	Magnet Attachments
29	Vacuum Supports
29	BUG-5910 Tube Carriage / Exploded View / Parts List
30-33	FMD Rail, Mounting and Carriages Options
30	Hi-Flex Rail / Cross Section / Exploded View / Parts List
31	FMD-2010 R.E. On/Off Magnet Assembly
31	FMD-1220 / FMD-1230 Hi-Flex Vacuum Supports and Vacuum Pump
32	FMD-1105 Hi-Flex Carriage / Exploded View
33	FMD-1105 Hi-Flex Carriage / Parts List
34	Vacuum Pump / Exploded View
35	Vacuum Pump / Parts List
36	ARV-1036 Vacuum Support Bar for ARR, AFR and BRR Rails
36	ARV-1036 Vacuum Support Bar / Exploded View / Parts List
37	FMD-1036 Vacuum Support Bar for FMD Rail / Exploded View / Parts List
38-43	Troubleshooting Guide
44	Notes
45	Master Drive Wiring Diagram / MPD-1000 / MPD-1002 / MPD-1004
46	Warranty

INTRODUCTION

The Arc Gouging Modular Drive System is the only product in the industry built using modular components. The system consists of a master drive, plug-in control module, and interchangeable carriages that are easily assembled.

The system runs in any position using Bug-O Rail (four options are available) which is held to the work surface by magnets or a vacuum system.

Rail options include:

- Aluminum Rigid Rail available in 8' (2.37 m) and 4' (1.18 m) lengths
- Aluminum Semi-Flex Rail available in 8' (2.37 m) length with a minimum bending radius of 15' (5 m)
- Bent Rigid Rail, bent to specific dimensions and dedicated to a specific inside or outside diameter. For working on Outside Diameters the smallest diameter is 20" (508 mm). For working on Inside Diameter the smallest diameter is 31" (787 mm)
- Hi-Flex Rail available in 5' (1.47 m) length with a minimum bending radius of 30" (760 mm)

The ARC Gouging configuration consists of a carriage, appropriate for the rail to be used, master drive, racking group and control module.

The Master Drive is rated at 60 lbs (27 kg) vertical load. The machine is equipped with overload protection.

STANDARD FEATURES

The Master Drive incorporates the following standard internal features:

- High torque, low inertia motor for precise starts and stops
- Dedicated fail-safe brake with three times the stopping and holding power of the motor
- Motor overload protection which turns off the motor and engages the brake when excessive load is placed on the machine
- Closed loop speed control for adjustable and repeatable control of arc gouging parameters
- Closed loop position control to prevent position creep when the machine stops

ADDITIONAL FEATURES

1. Arc Gouging Control Module
2. Master Drive is reconfigurable by the user for different applications, by changing carriages to run on different rail types
3. Clutch to enable rapid manual repositioning of the carriage anywhere on the track
4. Wheel engagement knob, which enables placement of the releasable carriage anywhere on the track
5. Optional cable mounting bar with anchor clamp to keep gouging, pneumatic, contact wires and power cables away from work surface
6. Contactor ON/OFF switch
7. Power Entry Box with:
 - a) Input Power Fuse
 - b) Machine ON/OFF Switch
 - c) Power Cord Mating Connector
8. Standard Carrying Handle
9. Digital Speed Display for increased control
10. Optional Carrying Handle and Mounting Bar
11. Gouging Contactor Receptacle

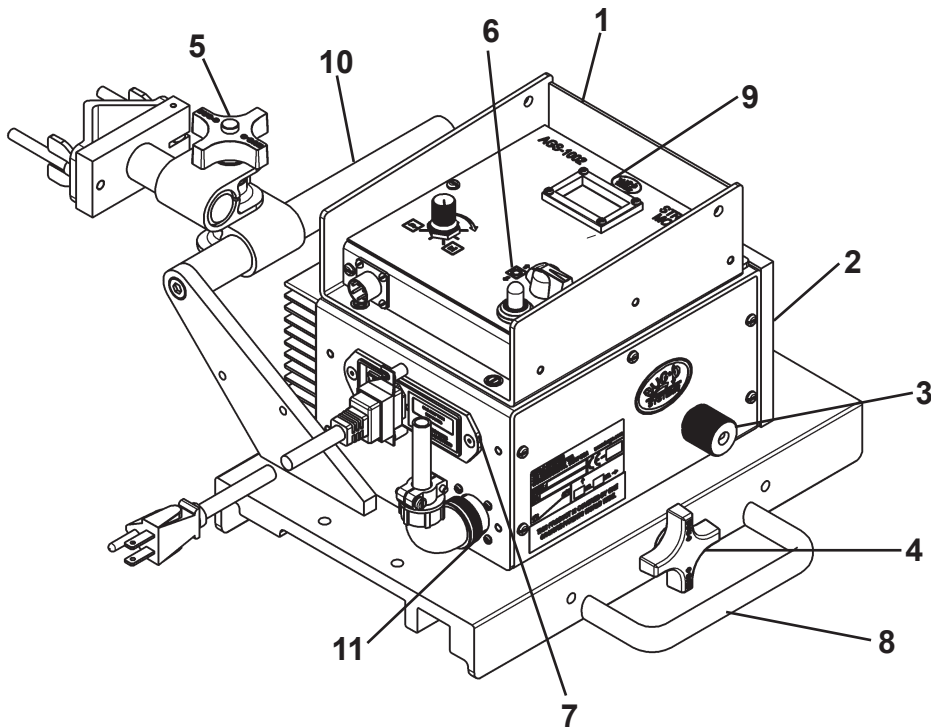

BUG-O TECHNICAL DATA

MASTER DRIVE UNIT

Power Requirements:

MPD-1000 120VAC/50-60Hz/1Ph 2Amp fuse
MPD-1002 240VAC/50-60Hz/1Ph 3Amp fuse

Dimensions: 7.75" L x 6.00" W x 4.25" H
 (197 L x 152 W x 108 mm H)

Load Capacity: Vertical 60 lbs (27 kg) **
 Horizontal 100 lbs (45 kg)

Speed Range: 2-120 in/min (51-3048 mm/min)

Net Weight: 10 lbs (4.5 kg)

Shipping Weight: 13 lbs (5.9 kg)

AGS CONTROL MODULE

Power Requirements:

AGS-1000 120VAC/50-60-Hz/1Ph (a)

Dimensions: 7.50" L x 6.00" W x 2.50" H
 (191 L x 152 W x 54 mm H)

Net Weight: 1.75 lbs (0.8 kg)

Shipping Weight: 3.0 lbs (1.4 kg)

DIMENSIONS

Master Drive Unit

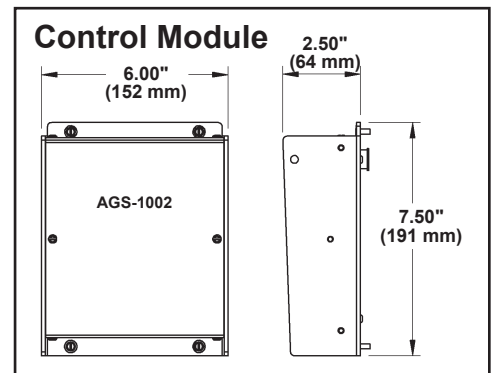
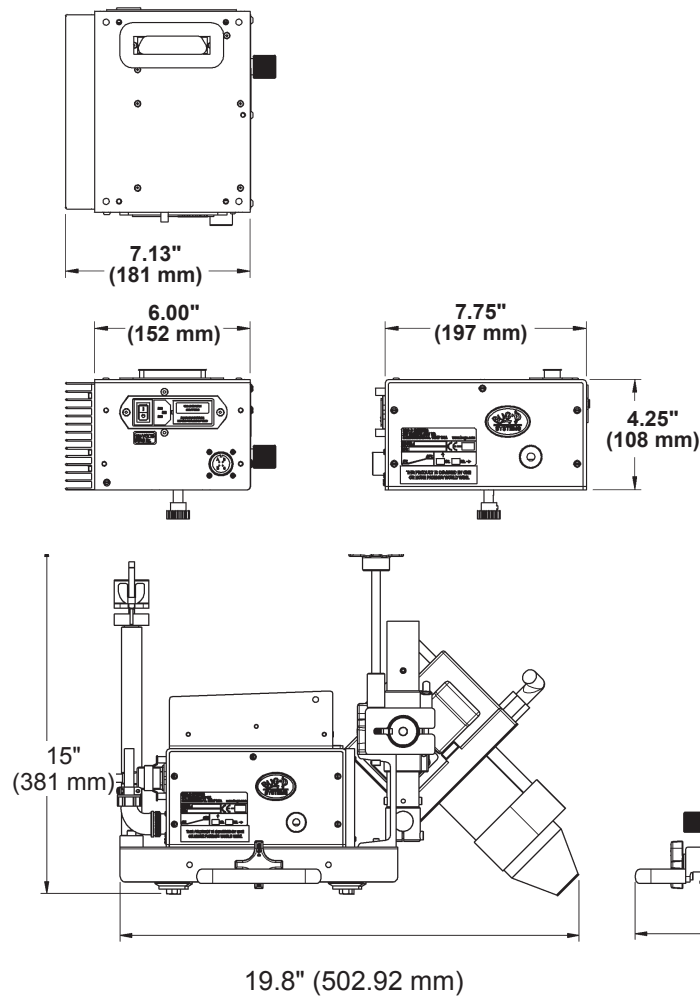

** The Master Drive Unit is rated at 60 lbs (27 kg) vertical load. The international Robotics Standards Rating requires a minimum of 2:1 continuous-duty safety margin on all power train and electronic components. The machine is equipped with overload protection.

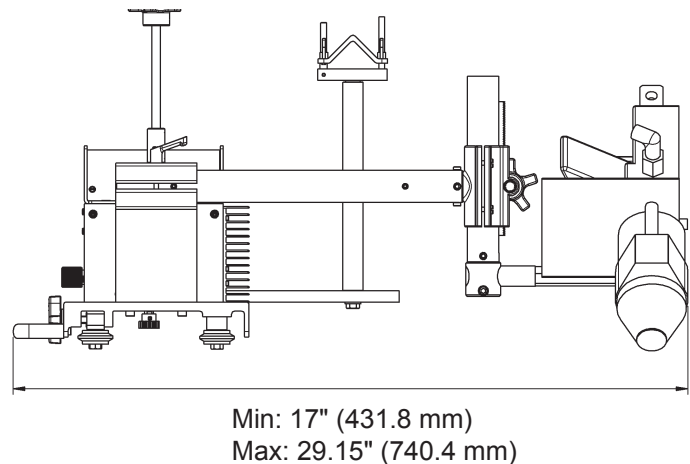

Arcair® N7500 TECHNICAL DATA

Power Requirements: N7500 120VAC/50-60Hz/1Ph
240VAC/50-60Hz/1Ph

Air Requirements: Pressure: 80 PSI (5.6 kg/cm²) (5.1 Bar)
Flow Rate: 63 CFM (17892.9 L/min)

Dimensions:

Remote Pendant: (5.5" W x 3.375" H x 9.25" D)
(140 W x 86 H x 235 mm D)

Net Weight: 2.4 lbs (1.08 kg)

Control Box: 14" W x 12.5" H x 10.75" D)
(355 W x 317 H x 273 mm D)

Net Weight: 29.8 lbs (13.5 kg)

Torch Head: 6.5" W x 9.5" H x 12.5" D)
(165 W x 241 H x 317 mm D)

Net Weight: 11.9 lbs (5.4 kg)



For a complete list of specifications and operating instructions refer to Arcair's N7500 Automatic Gouging System Operating Manual.

SYSTEM CONFIGURATIONS

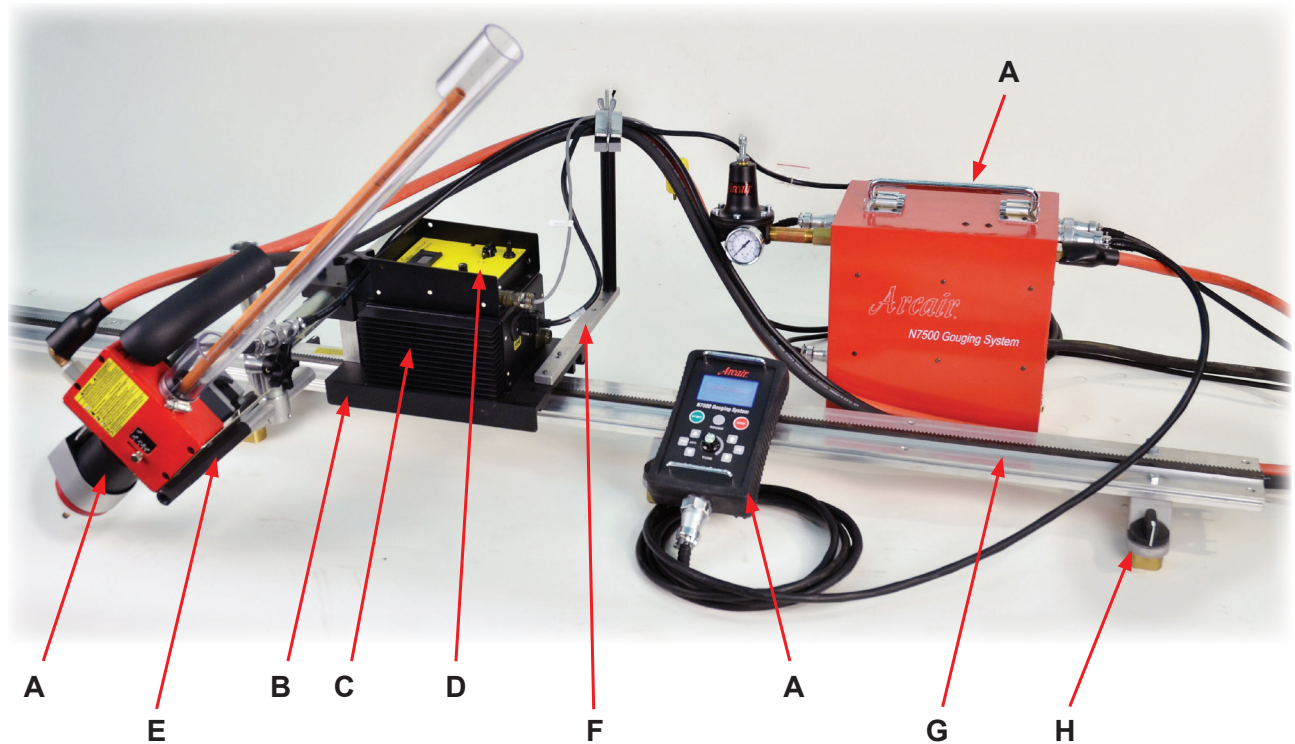

AGS-4000 MDS Gouging Kit for Rigid Rail 120 VAC

Includes:

<u>ITEM</u>	<u>PART NO.</u>	<u>QTY</u>	<u>DESCRIPTION</u>
A	AGS-4120	1	N7500 Arcair® Gouging System w/ Cables 120VAC
B-H	AGS-4050*	1	Rigid Gouging Bug-O Drive 120VAC

Includes:

<u>ITEM</u>	<u>PART NO.</u>	<u>QTY</u>	<u>DESCRIPTION</u>
B	MPD-1065	1	12" Releasable Carriage
C	MPD-1000 ⁺	1	Master Drive Unit 120VAC
D	AGS-1002	1	Arc Gouging Control Module
E	AGS-4172	1	Arcair® N7500 Mounting Group
F	BUG-2975	1	Cable Mounting Assembly
G	ARR-1080	1	Heavy Duty Aluminum Rail
H	ARM-2010	5	R.E. On/Off Magnet

AGS-4002 MDS Gouging Kit for Rigid Rail 240 VAC

Kit remains the same with the exception of the following changes:

*AGS-4052 Rigid Gouging Bug-O Drive 240VAC

⁺MPD-1002 Master Drive Unit 240VAC

SYSTEM CONFIGURATIONS, CONT'D.

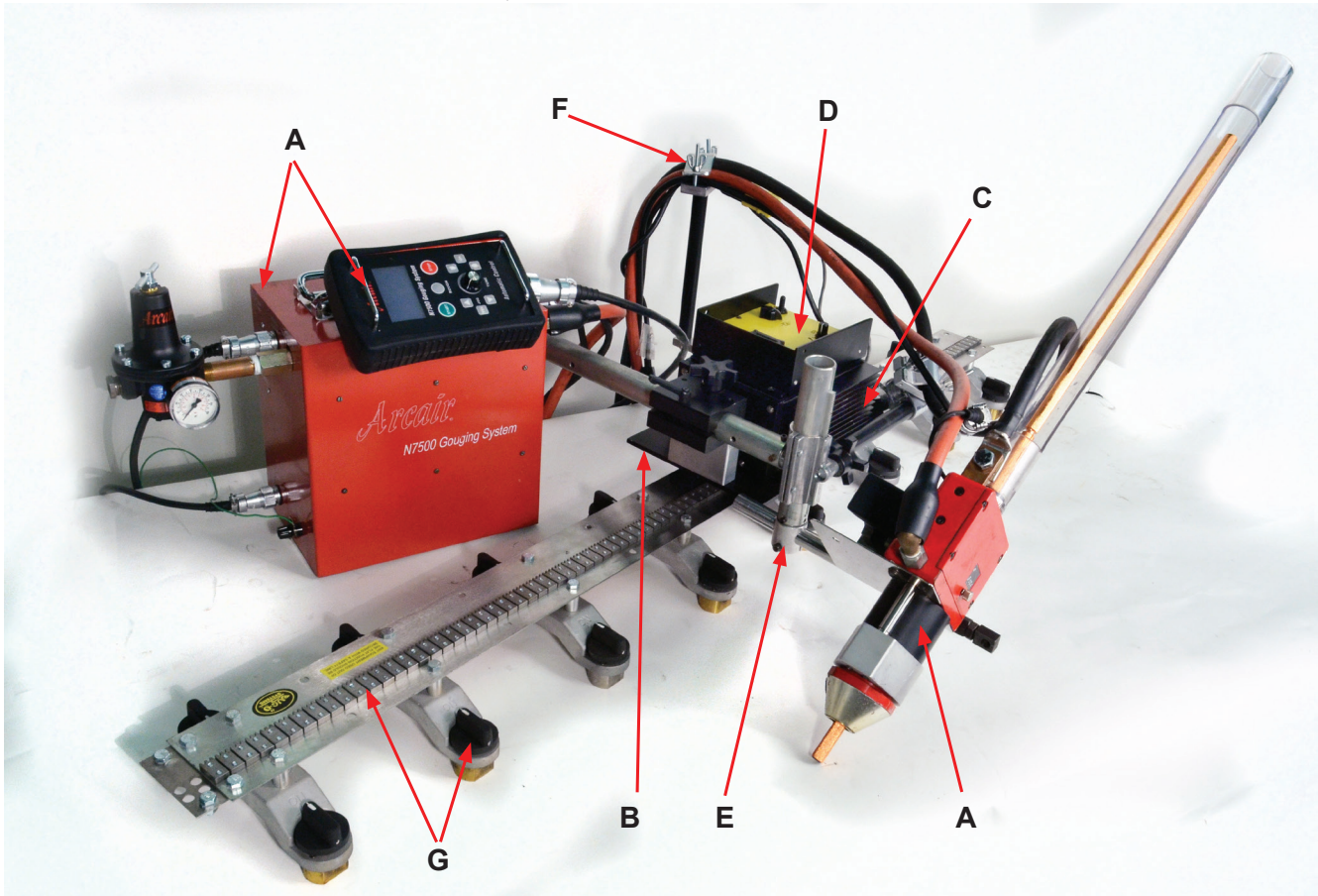

AGS-4100 MDS Gouging Kit for Hi-Flex Rail 120 VAC

Includes:

<u>ITEM</u>	<u>PART NO.</u>	<u>QTY</u>	<u>DESCRIPTION</u>
A	AGS-4120	1	N7500 Arcair® Gouging System w/ Cables 120VAC
B-G	AGS-4050*	1	Hi-Flex Gouging Bug-O Drive 120VAC

Includes:

<u>ITEM</u>	<u>PART NO.</u>	<u>QTY</u>	<u>DESCRIPTION</u>
B	FMD-1105	1	Hi-Flex Carriage w/ Handle & Clamp
C	MPD-1000 ⁺	1	Master Drive Unit 120VAC
D	AGS-1002	1	Arc Gouging Control Module
E	AGS-4172	1	Arcair® N7500 Mounting Group
F	BUG-2975	1	Cable Mounting Assembly
G	FMD-2170	1	Hi-Flex Rail w/ 8 R.E. On/Off Magnet

AGS-4102 MDS Gouging Kit for Hi-Flex Rail 240 VAC

Kit remains the same with the exception of the following changes:

*AGS-4052 Hi-Flex Gouging Bug-O Drive 240VAC

⁺MPD-1002 Master Drive Unit 240VAC

SYSTEM CONFIGURATIONS, CONT'D.

AGS-4172 Arcair® N7500 MOUNTING GROUP

<u>PART NO.</u>	<u>QTY</u>	<u>DESCRIPTION</u>
AGS-4173	1	Spacer Block
FAS-2359	2	Hex Hd Cap Scr 1/4 - 20 x 3-1/2"
BGV-1165-LS	1	Clamp Block Long Handle Shaft
BUG-5169-15	1	Rack w/ Torchholder, 15" Long
BUG-5178	1	H.D. Rack w/ Clamp
BUG-5173A	1	Rod
BUG-5173B	1	1/2 - 13 Threaded Stud, 1.5" Long

BUG-O Supplied Arcair® N7500 Automatic Gouging System

AGS-4020 N7500 Arcair® GOUGING SYSTEM 120VAC/240VAC

<u>PART NO.</u>	<u>QTY</u>	<u>DESCRIPTION</u>
AGS-4021	1	Remote pendant
AGS-4022	1	Control Box, 120VAC/240VAC
AGS-4023	1	Torch Head
AGS-4024	1	Air Regulator
AGS-4025	1	Electrode Holder

Arcair® N7500 Automatic Gouging System Spare Parts

Arcair® N7500 AUTOMATIC GOUGING SYSTEM SPARE PARTS

<u>PART NO.</u>	<u>QTY</u>	<u>DESCRIPTION</u>
AGS-4030	1	AC Power Supply Cable, 10 ft (3 m) 120VAC

AGS-4032 AC POWER SUPPLY CABLE, 10 ft (3 m) 240VAC

<u>PART NO.</u>	<u>QTY</u>	<u>DESCRIPTION</u>
AGS-4030	1	AC Power Supply Cable, 10 ft (3 m) 120VAC
BUG-9593	1	240VAC Twist-lock Plug
BUG-9594	1	240VAC Connector Body
BUG-9233	1	Label, 240V

AGS-4040 ARC GOUGING KIT CABLES

<u>PART NO.</u>	<u>QTY</u>	<u>DESCRIPTION</u>
AGS-4041	1	Power Supply Communication Cable, 25 ft (8 m)
AGS-3056	1	Air Hose Assembly, 25 ft (8 m)
AGS-4043	1	Remote Pendant Cable Assembly, 25 ft (8 m)
AGS-4044	1	Motor Cable Assembly, 25 ft (8 m)
AGS-3055	1	Power Cable Assy. 25 ft (8 m)
900-16-W10	1	Black 16ga Stranded 1000V Sensing Lead, 25 ft (8 m)
MWC-200	1	200 AMP On/Off Magnetic Ground

AGS-4120 N7500 Arcair® GOUGING SYSTEM & CABLES 120VAC

<u>PART NO.</u>	<u>QTY</u>	<u>DESCRIPTION</u>
AGS-4020	1	N7500 Arcair® Gouging System 120VAC/240VAC
AGS-4040	1	Arc Gouging Kit Cables
AGS-4030	1	AC Power Supply Cable, 10 ft (3 m) 120VAC

AGS-4122 N7500 Arcair® GOUGING SYSTEM & CABLES 240VAC

<u>PART NO.</u>	<u>QTY</u>	<u>DESCRIPTION</u>
AGS-4020	1	N7500 Arcair® Gouging System 120VAC/240VAC
AGS-4040	1	Arc Gouging Kit Cables
AGS-4032	1	AC Power Supply Cable, 10 ft (3 m) 240VAC

SETUP

1) POSITIONING THE RAIL (ARR, AFR)

Attach the rail parallel to the joint to be gouged. Position the rail using magnet plate or vacuum cups. Wipe the track grooves free of dirt and debris. This will prevent binding and premature rail and wheel wear. Lubricate the rack using a dry spray, if desired, for extended track life.

2) INSTALL CARRIAGE ON RAIL

2a) MPD-1065 CARRIAGE

Turn the wheel engagement knob **(A)** on the side of the carriage fully counter clockwise to disengage the wheels. Then rotate the Master Drive Unit clutch knob **(B)** fully counter clockwise to disengage the drive pinion. The carriage can now be placed anywhere on the track. Turn the wheel engagement knob **(A)** clockwise to engage the wheels firmly in the V-grooves. Verify all four wheels are in the grooves. Manually move the carriage along the track to verify the motion is smooth and the wheel alignment is correct. Rotate the Master Drive Unit clutch knob **(B)** fully clockwise while gently rocking the machine forward and backward to engage the drive pinion. The rocking motion is necessary to help insure proper gear mesh.

2b) POSITIONING BUG-5910* TUBE CARRIAGE ONTO ARR, AFR OR BRR RAIL

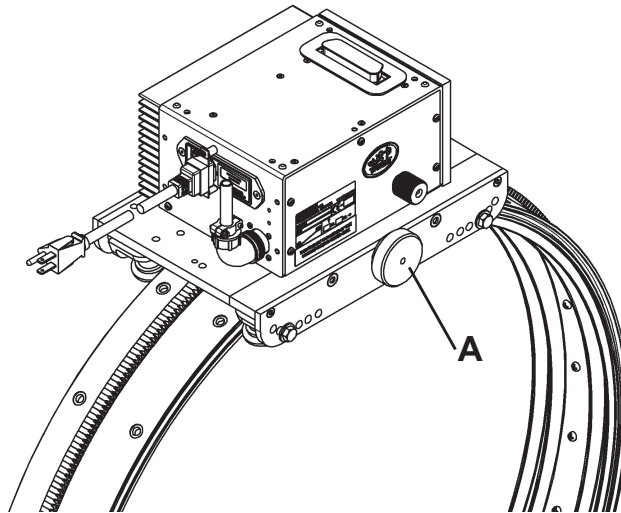

BUG-5910 TUBE CARRIAGE

The Tube Carriage features a split carriage body for quick and easy placement on the rail. It has a carrying capacity of 100 lbs (45 kg). The carriage also offers four (4) wheel positions for circumferential applications over a wide range of diameters and flat applications. It is used with BUG-O Aluminum Rigid Rail, Extra Heavy Duty Aluminum Rigid Rail, Semi-Flex Rail and Bent Rigid Rail.

** BUG-5910 is the only carriage that will mount to BRR rail. It will also mount to ARR and AFR rails with some adjustments.*

SETUP, CONT'D.

2c) INSTALLING BUG-5910 TUBE CARRIAGE

1. Select the correct pair of holes on each side of the carriage for the rail diameter being used (see chart). If the wheels are not attached to the correct set of holes, remove them and bolt the wheel brackets in selected holes. Tighten the bolts until the brackets are snug, but still free to rotate.

2. Use the wheel engagement knob (A) to open the split carriage. On the drive unit, loosen and turn the clutch knob (B) counter clockwise to declutch the drive pinion.

Carriage Wheel Hole Set	BRR-1210 Rail ID		Pipe OD	
	in	mm	in	mm
A	20 - 25	500 - 635	9 - 21	230 - 530
B	23 - 35	585 - 890	12 - 31	300 - 790
C	30 - 44	760 - 1120	18 - 40	455 - 1015
D	41 - 60	1040 - 1525	29 - 54	735 - 1375
E	75 - 174	1905 - 4420	64 - 170	1625 - 4320
F	flat rail		flat rail	

Note: Chart values are for reference only

3. Place the carriage on the rail with the wheels in the rail grooves. Use the wheel engagement (A) knob to close the carriage then move the carriage back and forth a few inches. The wheels on their mounting brackets will align themselves correctly in the rail grooves.
4. Verify that the wheels are properly aligned, then tighten the wheel mounting bolts to lock them in position. Rotate the clutch knob (B) clockwise while gently rocking the carriage back and forth to engage the drive pinion with the rack.
5. Verify that the pinion is properly engaged in the rack. The correct wheel position will provide a minimum of 1/8" (3 mm) engagement between the drive pinion and the rack.

NOTE: The pinion height may need to be adjusted for some rail or pipe sizes.

6. Position and clamp the weld gun, cutting torch, cables, etc. and proceed with the operation.

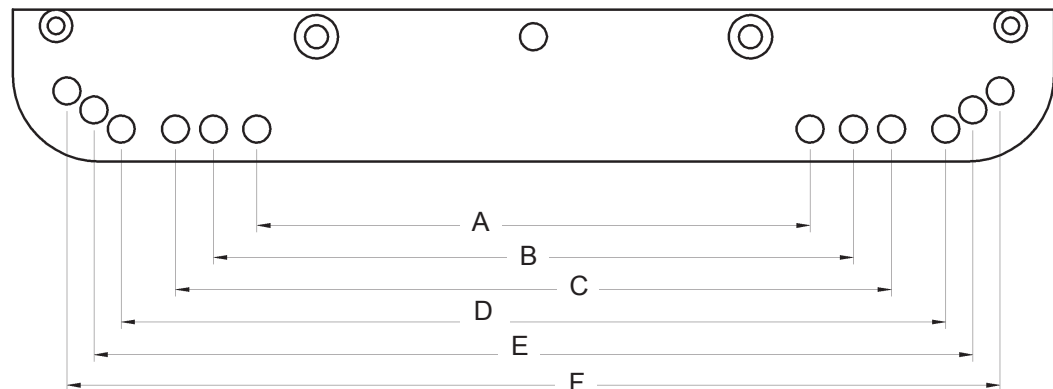

SETUP, CONT'D.

2d) POSITIONING FMD-1105 HI-FLEX CARRIAGE ON TO FMD HI-FLEX RAIL

The Hi-Flex Carriage has a carrying capacity of 100 lbs (45 kg). Used ONLY on Hi-Flex Rail (FMD-1050).

Turn the wheel engagement knob **(A)** on the side of the carriage fully counter clockwise to disengage the wheels. Then rotate the Master Drive Unit clutch knob **(B)** (below) fully counter clockwise to disengage the drive pinion. The carriage can now be placed anywhere on the track. Turn the wheel engagement knob **(A)** clockwise to engage the rail firmly in the V-groove of the bearing wheels. Manually move the carriage along the track to verify the motion is smooth and the wheel alignment is correct. Rotate the Master Drive Unit clutch knob **(B)** fully clockwise while gently rocking the machine forward and backward to engage the drive pinion. The rocking motion is necessary to help insure proper gear mesh.

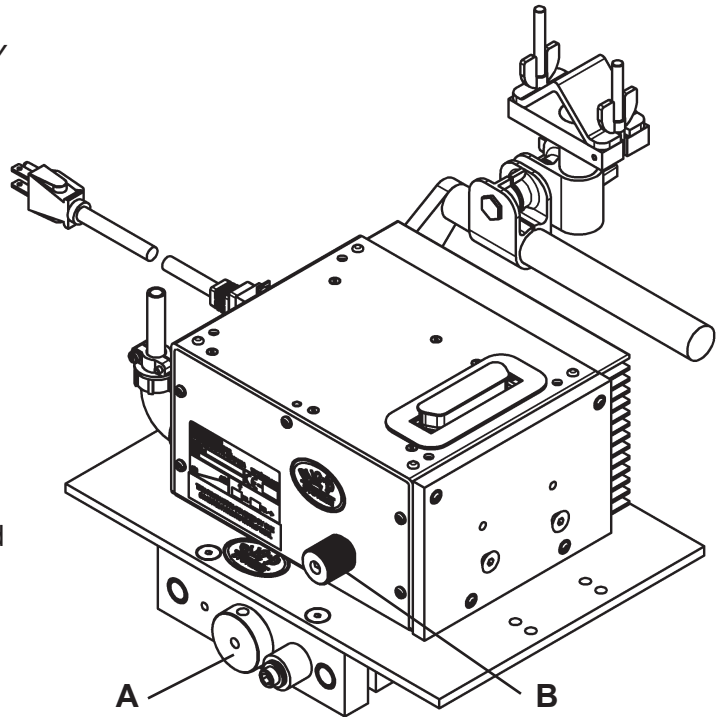

FMD-1105 Hi-Flex Carriage

3) WHEEL ADJUSTMENT AND ALIGNMENT ON ARR, AFR AND BRR RAILS

Always check for proper carriage wheel adjustment before using the machine. Turn the wheel engagement knob **(A)** on the side of the carriage until the wheels are fully moved towards the center of the carriage (engaged). Then rotate the master drive clutch knob **(B)** fully counter clockwise to disengage the drive pinion. Slide the carriage onto the end of the track. The wheels should slide into the V-grooves and the carriage will move smoothly along the track if the wheels are properly aligned.

The wheels along one side of the carriage have stainless steel shim washers **(C)** underneath. These wheels are adjustable. Readjust these wheels (if necessary) by rotating the hex bolt **(D)** with a 1/2" wrench.

Grasp the sides of the carriage. The wheels are too loose if it is possible to move the carriage from side to side or up and down. Use a finger to keep one of the adjustable wheels from rotating as the carriage is manually pushed along the track. The wheels are too tight if firm finger pressure is not enough to prevent wheel rotation. Repeat the process for the other adjustable wheel.

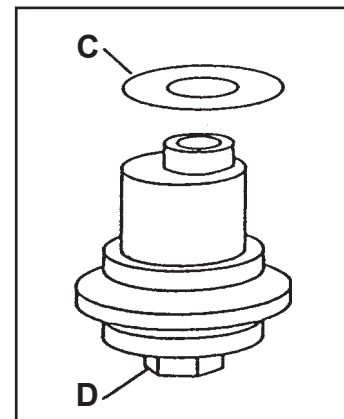
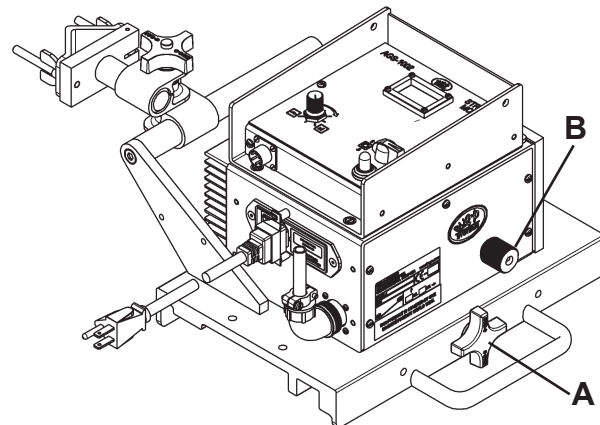

SETUP (CONT'D.)

4) REMOTE CONTACTOR WIRING

Connect to the Right Side of ARC GOUGING Control Box 120VAC outlet, see page 16.
Pins A and B Connection for Arc Gouger

5) ARC GOUGING HEAD SET-UP

Install AGS-4172 Arcair® N7500 Mounting Group to the front of the BUG-O Carriage.

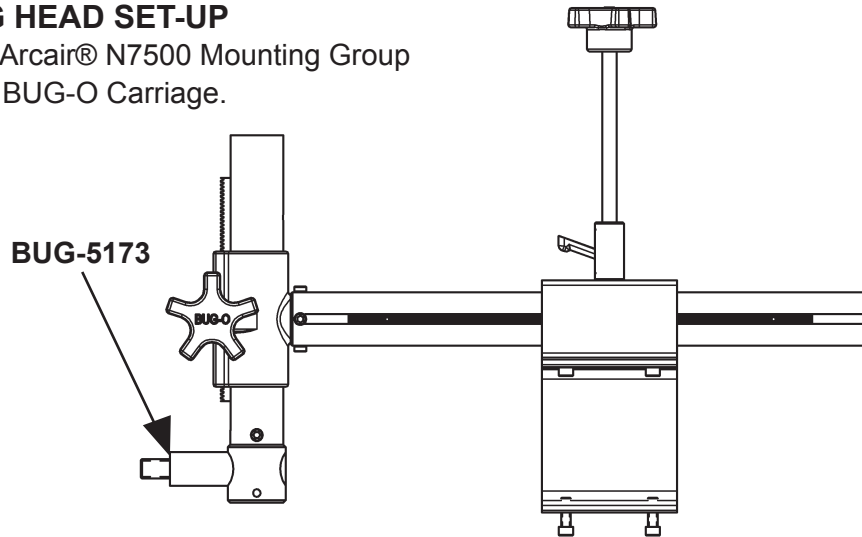

AGS-4172 Arcair® N7500 Mounting Group

The “TORCH HEAD” of the N7500 Automatic Gouging System is mounted to BUG-5173 of AGS-4172 Arcair® N7500 Mounting Group.

The attachment is made at this location, from either side of the head.

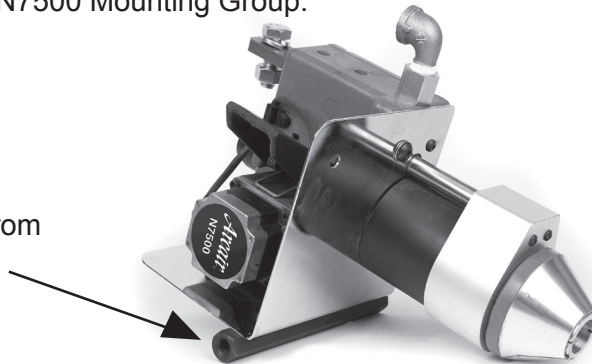

Arcair® “TORCH HEAD”

6) POSITION “TORCH HEAD”

- Position the Torch Head above the work piece.
- Using the Angle Gauge supplied with the N7500, adjust the Torch head to the work piece.
The angle gauge sets the torch angle and electrode stick-out and aligns the nozzle.
- The air should flow between the electrode and the work piece.

Charts, graphs and other data in this manual are based on a 45° electrode angle, but you can use electrode angles from 45° to 60°. Users should develop their own standards based on shop conditions and application.

SETUP (CONT'D.)

7) CONNECTING POWER TO ARC GOUGING MODULE

Plug the Master Drive Unit power cord into the appropriate power supply, MPD-1000 into 120VAC/50-60Hz/1Ph or MPD-1002 into 240VAC/50-60Hz/1Ph.

Plug the Arcair® N7500 Automatic Gouging System into the appropriate power supply 120VAC/50-60Hz/1Ph or into 240VAC/50-60Hz/1Ph.

Plug the AGS-1002 ARC Gouging Control Module into the 120VAC Power Outlet on the N7500 Control Box.

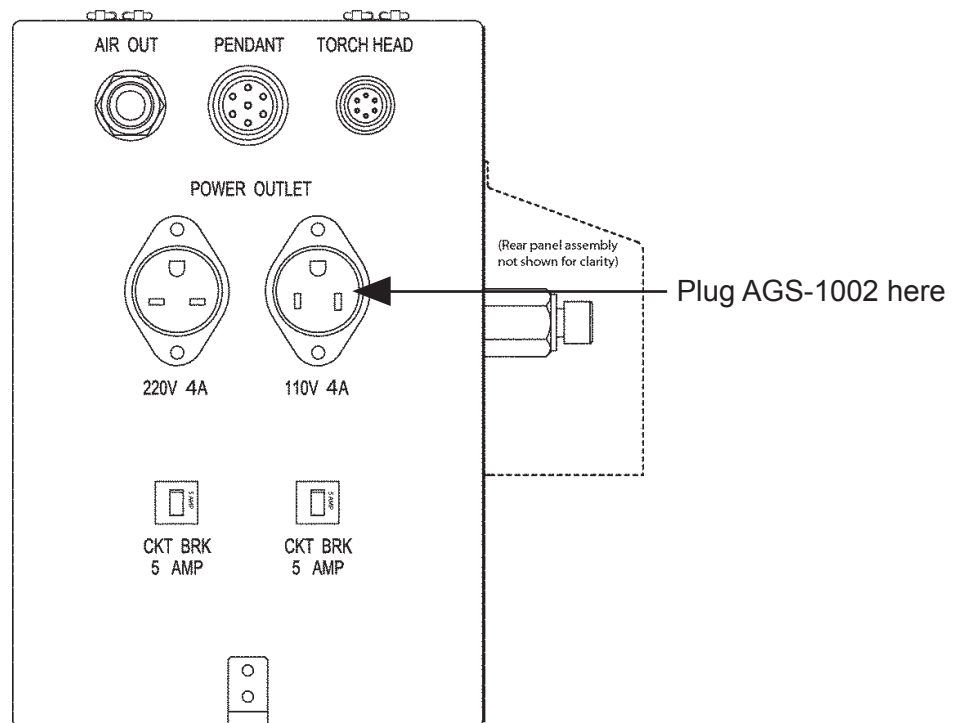

NOTE: This is the only location to plug the AGS-1002 Power Cord to. Not doing so WILL prevent proper operation of the BUG-O Tractor System and Gouging System.

Complete setup and installation of Arcair® N7500 Automatic Arc Gouging System according to their instructions. When completed both BUG-O and Arcair® systems should be ready to operate.

8) ALIGNMENT

With TORCH HEAD mounted and set to proper angle, adjust the left right and vertical racks to align Carbon rod with joint to be gouged. Tighten firmly in place and begin.

IMPORTANT!

DO NOT permit CARBON ROD to touch plate. Set a minimum of 1/8" from tip of carbon rod to work surface. Failing to heed this precaution could lead to irreparable damage to TORCH HEAD, CONTROL BOX, PENDANT, MASTER DRIVE, ARC GOUGING CONTROL MODULE and **IS NOT covered under warranty.**

ARC GOUGING MODULE

MACHINE OPERATION

Turn the main power “ON” at the power entry box. Set the following parameters on the AGS-1002 ARC Gouging Control Module

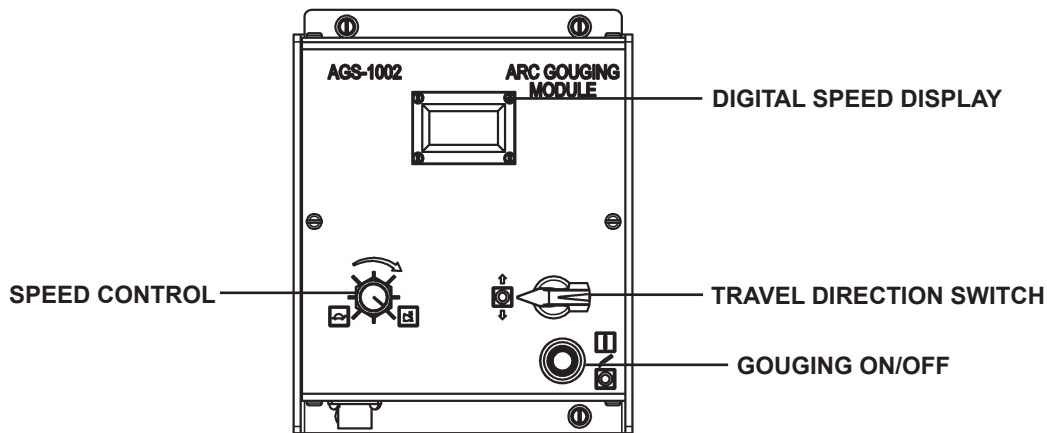

SPEED CONTROL: Sets the tractor speed from 2-120 in/min (5.1-304.8 mm/min).

CARRIAGE TRAVEL SWITCH: Provides **FORWARD/STOP/REVERSE** direction control.

DIGITAL READOUT: The display is dual function.

- a) **PRESET SPEED** - Displayed when the **CARRIAGE TRAVEL SWITCH** is **OFF** or motion is halted by a motor overload condition.
- b) **MEASURED SPEED** - Displayed when power is applied to the motor.
(This will be the same as the Preset Speed.)

The readout is factory set to display the carriage speed in in/min for 120VAC systems and cm/min for 240VAC systems. The display can be rescaled as required, or readjusted to read in/min by following the instructions found in the “**DIGITAL READOUT CALIBRATION**” section of this manual (pg. 18).

GOUGING ON/OFF: Opens/closes a pair of independent 1 Amp contacts (pins A & B) at the arc contactor receptacle.

NOTE: A safety interlock will automatically open the ARC Gouging contacts in the motor overload protection halts machine motion. Clear the overload by turning the Direction Travel Switch to OFF. Resetting the overload fault will not cause the contacts to automatically reclose. Use the GOUGING ON/OFF switch to restart the ARC Gouging unit after clearing the overload.

REPLACEMENT POTS AND SWITCHES

DIRECTION TRAVEL SWITCH:

Switch and Spacer	MDS-1112
Black Pointer Knob	BUG-9694

SPEED CONTROL:

10K Ω Pot., 3-3/4 Turn	PCB-1026
Black Knob	MDS-1018
Knob Seal Nut	MDS-1046

GOUGING ON/OFF:

Switch and Spacer	MDS-1114
Toggle Switch Boot	MDS-1047

DIGITAL READOUT CALIBRATION

Internal Control Module adjustments enable the user to change between the factory-set in/min (120 VAC) and cm/min (240 VAC). The display can also be recalibrated, if required, to give an accurate speed readout.

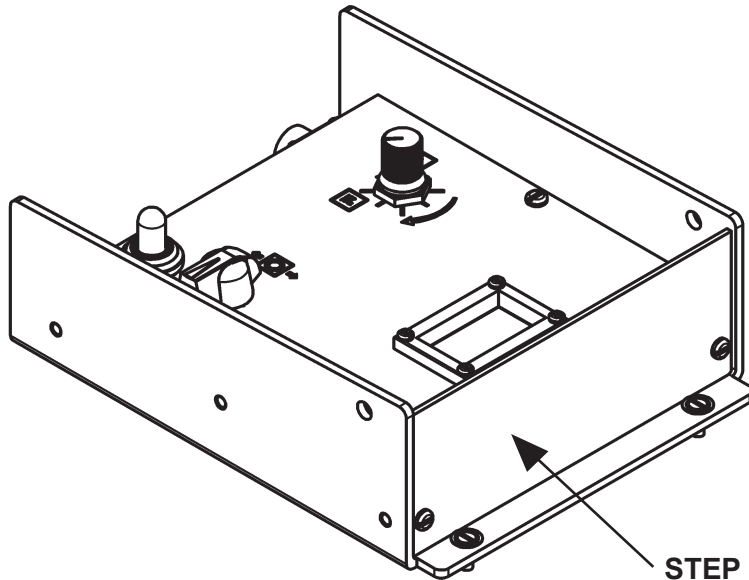

STEP 1: Remove endplate

STEP 2: Set Switch 1 & 2

	SW 1	SW 2
in/min	Down	Down
cm/min	Up	Down

STEP 3: Apply power to the Modular Drive. Maximize the tractor speed using the Control Module front panel

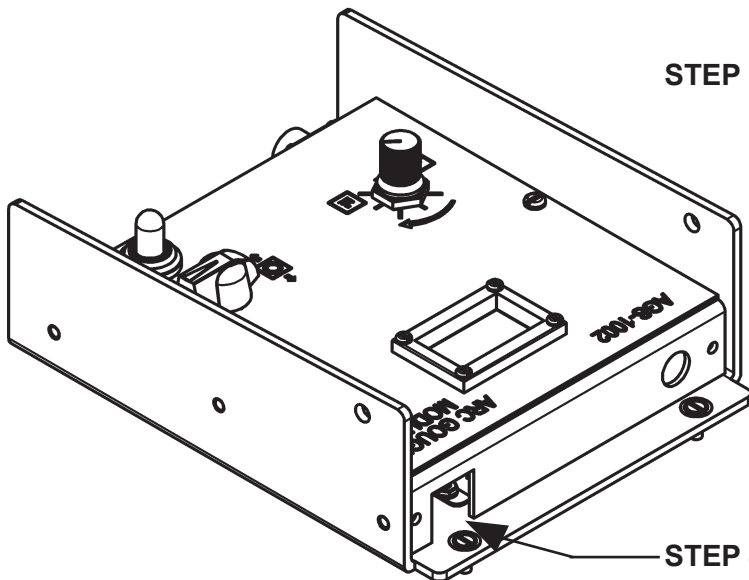

STEP 4: Set the speed display using a small slotted screwdriver

STEP 5: Reinstall endplate

AGS-4172 Arcair® MOUNTING GROUP / EXPLODED VIEW / PARTS LIST

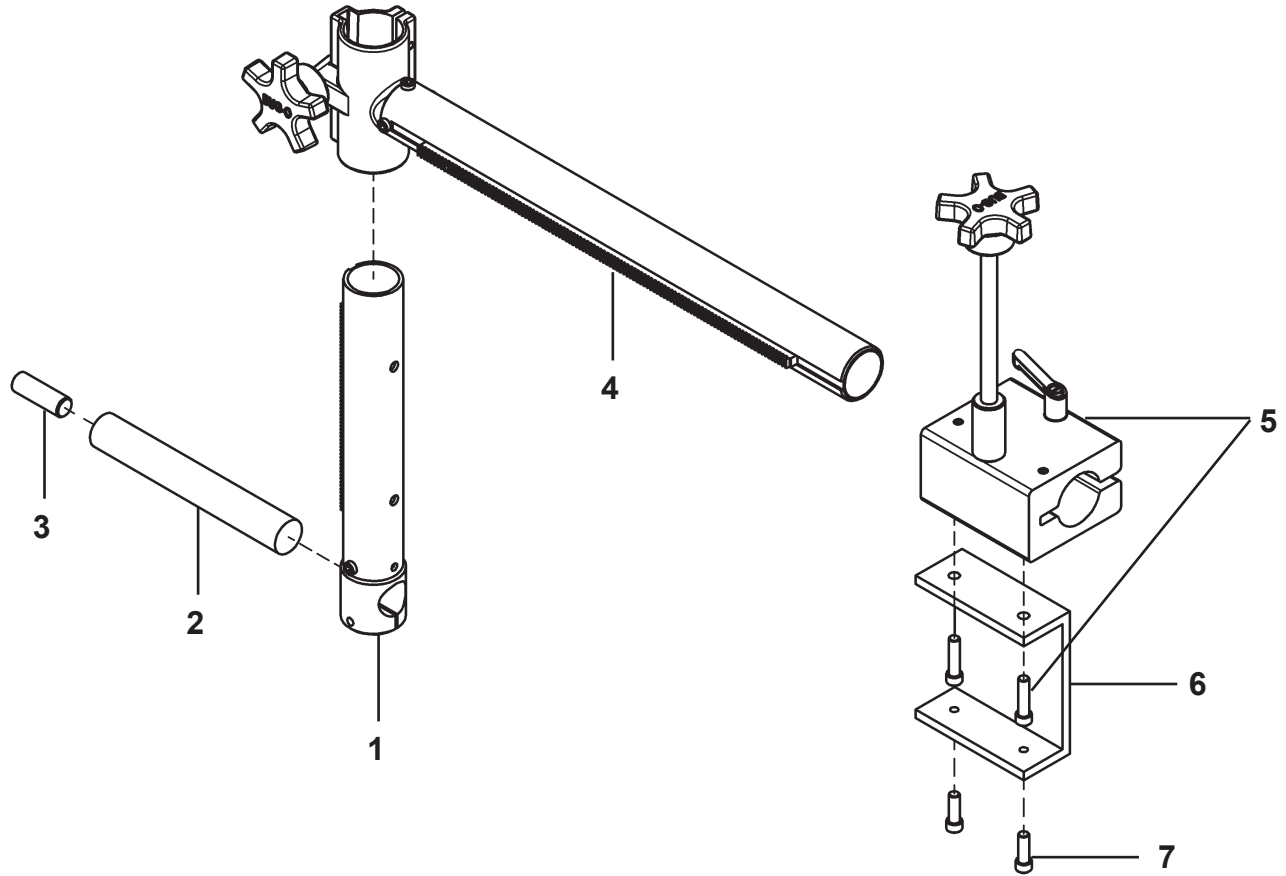

PARTS LIST

<u>ITEM</u>	<u>PART NO.</u>	<u>DESCRIPTION</u>	<u>QTY</u>
1	BUG-5178	H.D. 8" Rack w/ Clamp	1
2	BUG-5173A	Rod	1
3	BUG-5173B	1/2-13 Threaded Stud	1
4	BUG-5169-15	H.D. Rack w/ Torchholder 15"	1
5	BGV-1165-LS	Clamp Block Long Handle Shaft	1
6	AGS-4173	Spacer	1
7	FAS-0557	Soc Hd Cap 1/4-20 x 3/4	2

MPD-1000 MASTER DRIVE UNIT / EXPLODED VIEW

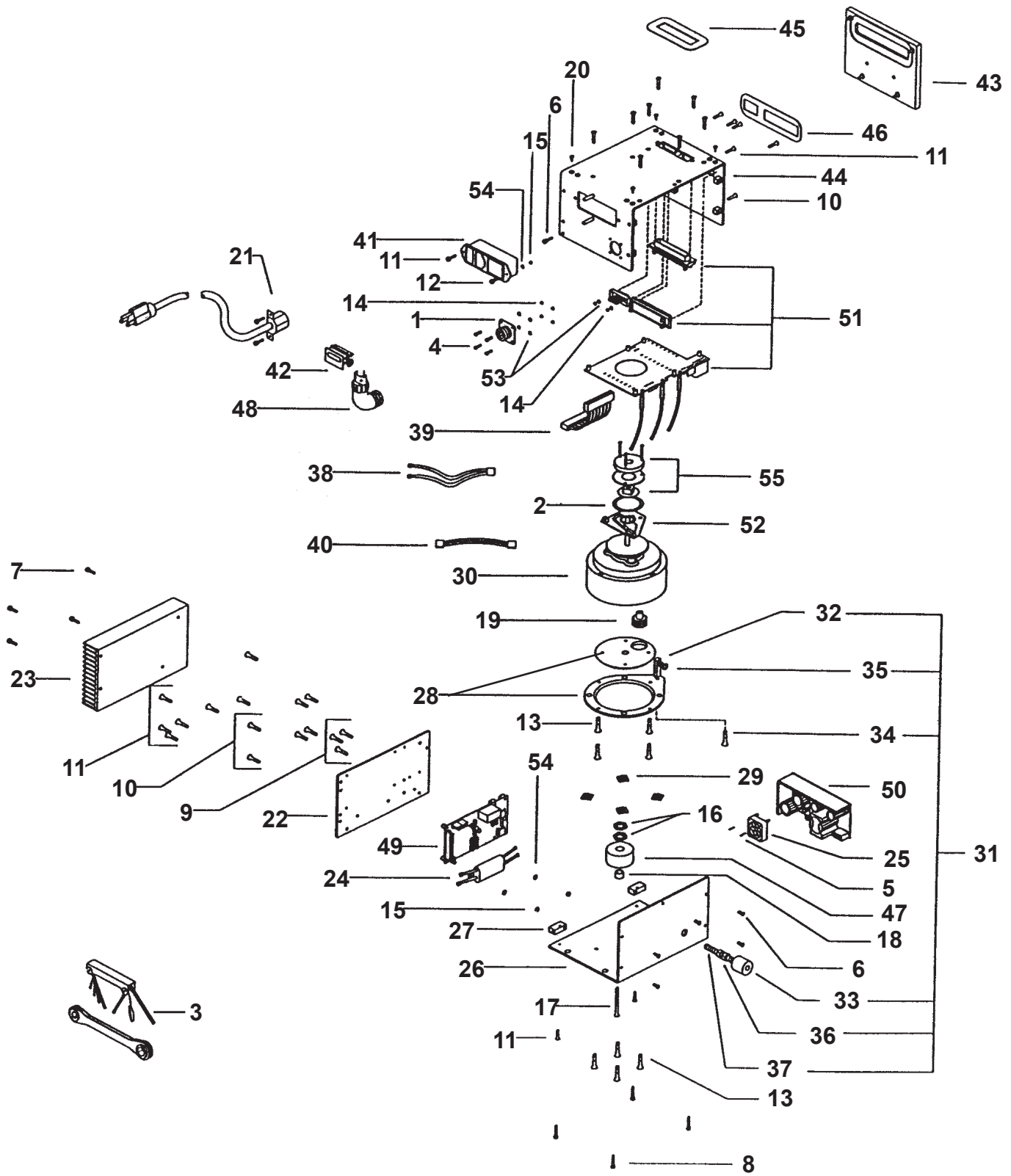

MPD-1000 MASTER DRIVE UNIT / PARTS LIST

<u>ITEM</u>	<u>PART NO.</u>	<u>DESCRIPTION</u>	<u>QTY</u>
1	BUG-1034	Panel Connector, 4-T, Male	1
2	WPD-1013	Rubber Ring Gasket	1
3	BUG-9444	Tool Kit	1
4	FAS-0104	Pan Hd Screw #4-40 x 318 Long	4
5	FAS-0107	Pan Hd Screw #4-40 x 3/4 Long	2
6	FAS-0114	Pan Hd Screw #6-32 x 3/8 Long	6
7	FAS-0504	Soc Hd Cap Scr #4-40 x 3/8 Long	4
8	FAS-0557	Soc Hd Cap Scr 1/4-20 x 3/4 Long	4
9	FAS-0902	Flt Hd Soc Scr #4-40 x 1/4 Long	3
10	FAS-0905	Flt Hd Soc Scr #4-40 x 1/2 Long	19
11	FAS-0914	Flt Hd Soc Scr #6-32 x 3/8 Long	11
12	FAS-0915	Flt Hd Soc Scr #6-32 x 1/2 Long	1
13	FAS-0923	Flt Hd Soc Scr #8-32 x 5/16 Long	8
14	FAS-1305	Hex Nut #4-40	6
15	FAS-1310	Hex Nut #6-32	3
16	FAS-1325	Hex Nut #8-32 Nylon	2
17	FAS-2823	Flt Hd Slit Scr #8-32 x 1-1/2 Long	1
18	GOF-3012	Spacer 1/2 OD x 5/16 Long	1
19	GOF-3014	Drive Pinion w/ Key and Set Screw	1
20	MDS-1019	Snap Rivet, Black	4
*21	MPD-1001	Power Cord 120 VAC	1
22	MPD-1006	Side Panel	1
23	MPD-1007	Heat Sink	1
24	MPD-1008	Filter	1
25	MPD-1009	Fan Assembly	1
26	MPD-1011	Base Panel	1
27	MPD-1012	Mounting Block	1
28	MPD-1090	Matched Clutch Plates	2
**29	BUG-2593	Glide Flat	1
30	MPD-1015	Gear Motor (60:1)	1
31	MPD-1016	Clutch Assembly (Includes items 32 through 37)	1
32	BUG-1216	Ball Joint	1
33	BUG-1857	Knob	1
34	FAS-0945	Fit Hd Soc Scr #10-32 x 1/2 Long	1
35	FAS-1341	Hex Jam Nut #10-32	1
36	FAS-1390	Hex Nut 3/8-16	2
37	MPD-1017	3/8-16 Threaded Stud	1
38	MPD-1018	Wiring Harness-Speed Board to Motor	1
39	MPD-1019	Wiring Harness-Interconnect to Speed Bd/Control	1
40	MPD-1020	Wiring Harness-Interconnect to Speed Bd/Power	1
41	MPD-1025	Power Entry Module	1
* 42	MPD-1026	Fuse 2A	1
43	MPD-1029	Connector Cover Plate	1
44	MPD-1031	Cover Panel (Includes item # 20)	1
45	MPD-1038	Gasket for 50-Pin Connector	1
46	MPD-1039	Gasket for 50-Pin/3-Pin Connector	1
47	MPD-1042	Inductor, Potted-with Connectors	1
48	MUG-1617	Cable Connector, 4-T, Female, Elbow	1
*49	PCB-1000	Speed Board	1
* 50	PCB-1005-120	Power Supply Assembly 165W 120 VAC	1
51	PCB-1010	Interconnect Board	1
52	PCB-1012	Position Card	1
53	WAS-0201	#4 Internal Star Lockwasher	6
54	WAS-0211	#6 Internal Star Lockwasher	3
55	WPD-1012	Brake Assembly	1

* See Electrical Component Chart for 240 VAC Part Numbers

**Included in Item 28.

AC POWER WIRING DIAGRAM

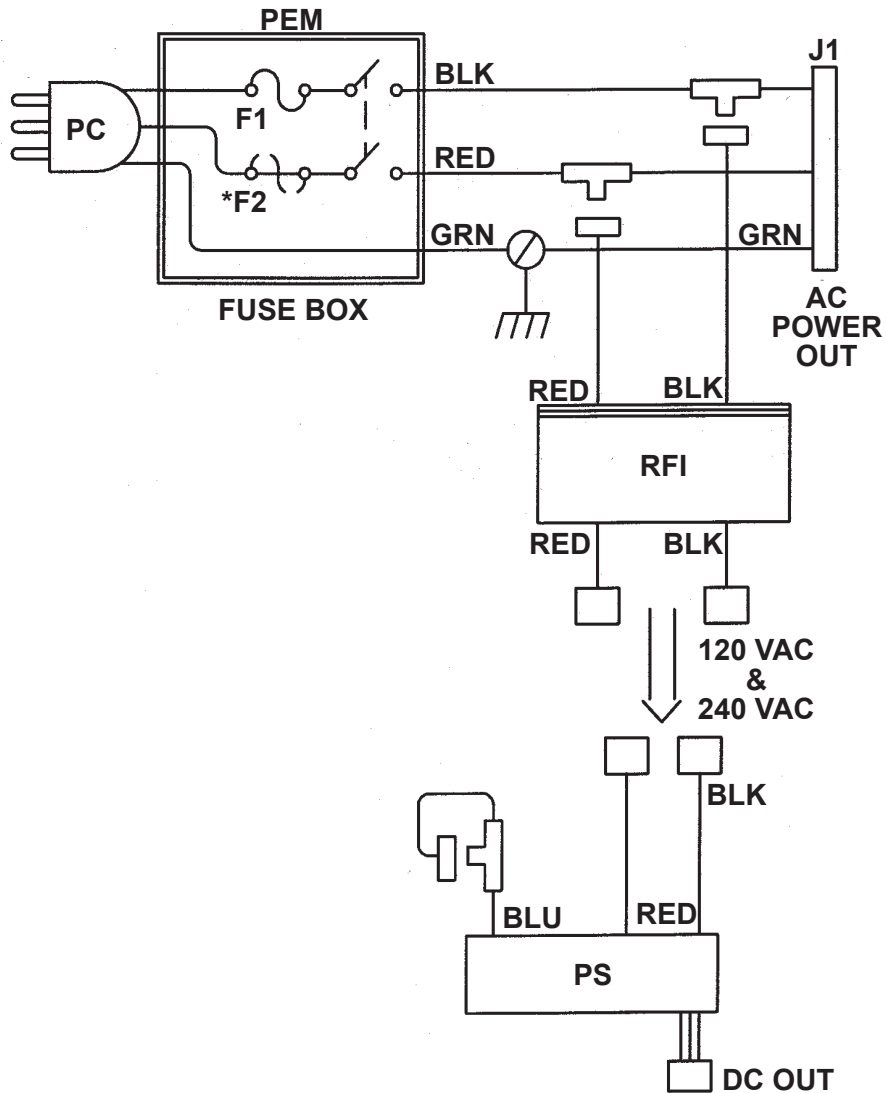

ELECTRICAL COMPONENT CHART

ITEM	DESCRIPTION	PART NUMBER	
		MPD-1002 120 VAC	MPD-1004 240 VAC
F1,F2*	Fuses	(1) MPD-1026 2A	(2) MPD-1027 3A
PC	Power Cord	MPD-1001	MPD-1003
PS	Power Supply	PCB-1005-120	PCB-1005-240
J1	Connector w/Pins	MPD-1021	
PEM	Power Entry Module	MPD-1025	
RFI	Filter Module	MPD-1008	
*F2 replaced with bus wire on 120 VAC			

SIGNAL WIRING

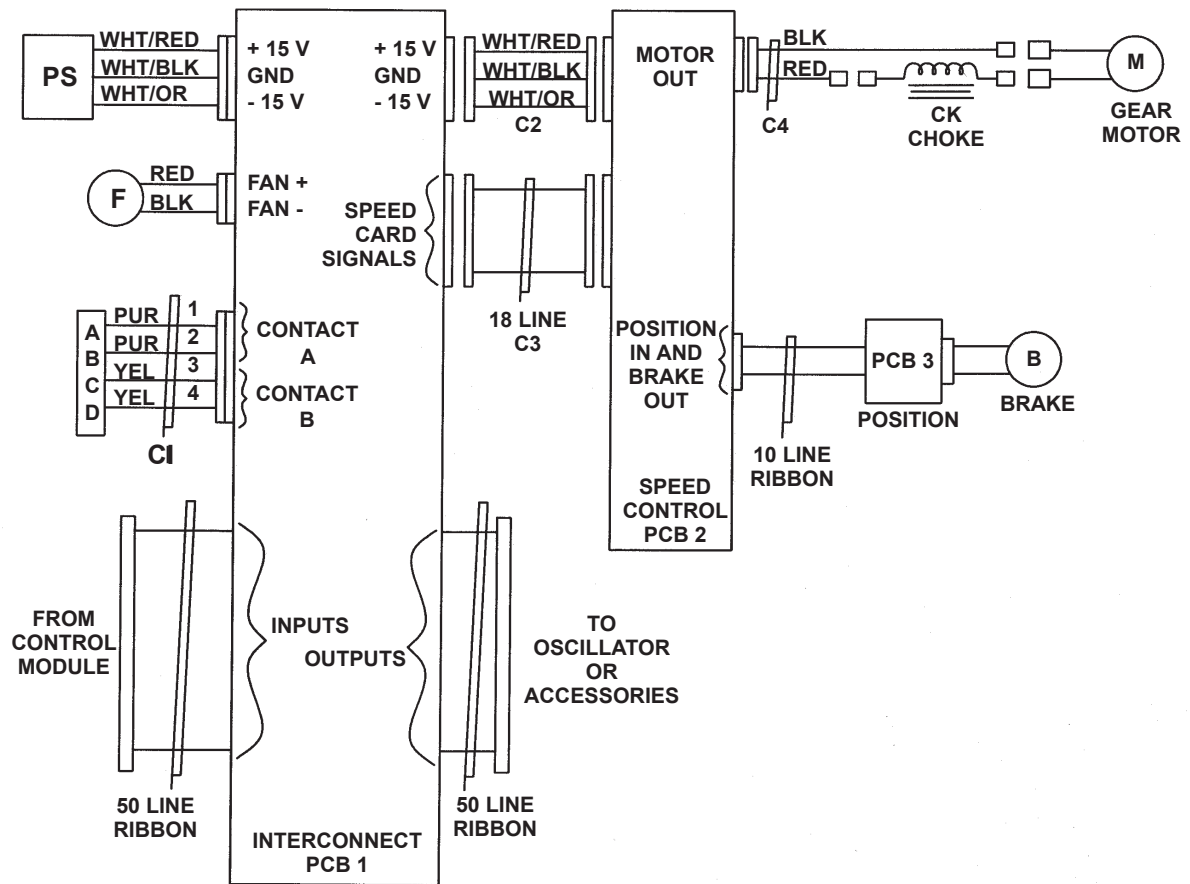

PARTS LIST

ITEM	DESCRIPTION	PART NUMBER
B	Brake Assembly	WPD-1012
CI	Contact Cable Assembly	MPD-1036
C2	DC Power Cable Assembly	MPD-1020
C3	Speed Card Cable Assembly	MPD-1019
C4	Motor Wiring	MPD-1018
CK	Inductor Pot Assembly (Choke)	MPD-1042
F	Fan Assembly	MPD-1009
M	Gear Motor	MPD-1015
PCB1	Interconnect Card	PCB-1010
PCB2	Tractor Speed Card	PCB-1000
PCB3	Position Sensor Card	PCB-1012
PS	Power Supply	(see AC Wiring Diagram)

ALUMINUM RIGID RAIL / CROSS SECTION / EXPLODED VIEW / PARTS LIST

ALUMINUM RIGID RAIL is a rigid channel section made of high quality alloy to machine tool tolerance as in the section view below. A machined gear rack is mounted on the rail, with which the drive pinion of the carriage meshes. The wheels of the carriage travel in opposed grooves at either side of the rail, locking the carriage to the rail.

Heavy Duty (H.D) aluminum four-legged rigid rail is supplied in two lengths:

- ARR-1080 [93-1/2" (2.37 m)] called 8' (2.37 m) rail
- ARR-1085 [46-1/2" (1.18 m)] called 4' (1.18 m) rail

Extra Heavy Duty aluminum four-legged rigid rail is also available:

- ARR-1250 [93-1/2" (2.37 m)] called 8' (2.37 m) rail
- ARR-1200 [46-1/2" (1.18 m)] called 4' (1.18 m) rail

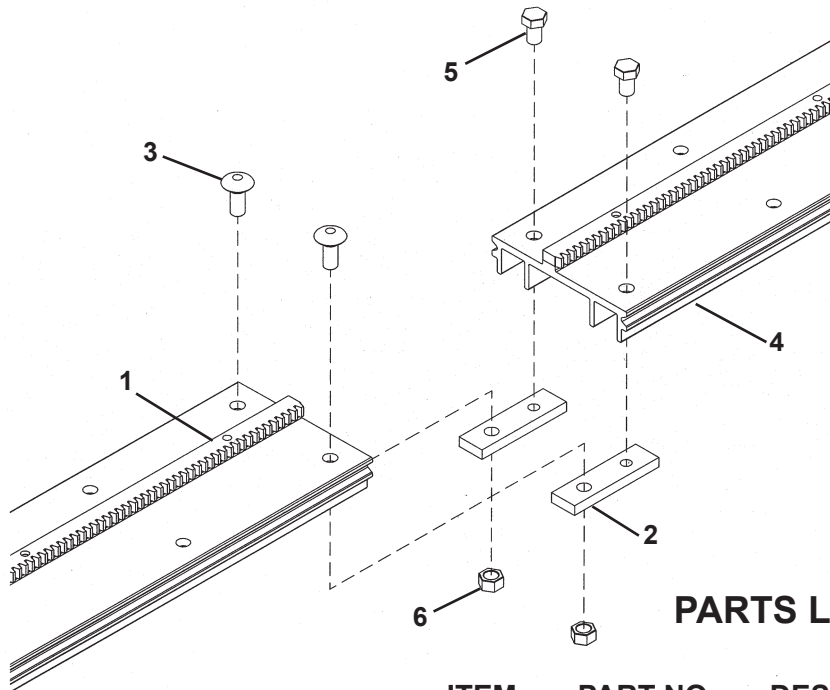
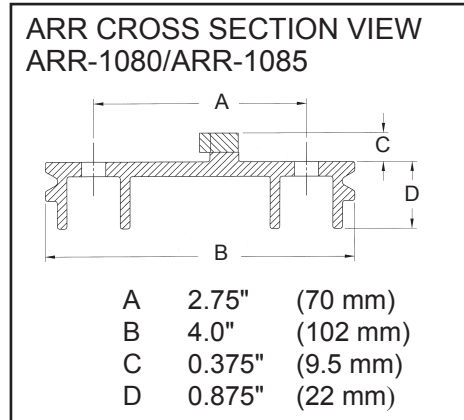

PARTS LIST - ARR-1080 (ONLY)

<u>ITEM</u>	<u>PART NO.</u>	<u>DESCRIPTION</u>	<u>QTY</u>
1	ARR-1002	Rack	1
2	ARR-1027	Splicer Bar	2
3	ARR-1028	Carriage Bolt	2
4	ARR-1081	Rail Extrusion	1
5	FAS-0375	Hex Hd Cap Scr 5/16-18x1/2	2
6	FAS-1370	Hex Nut 5/16-18	2

(Consult Factory for parts to ARR-1085, ARR-1250 or ARR-1200)

RAIL FOR LONGER SPANS:

When unsupported rail paths longer than 8' (2.37 m) rail are required, multiple sections of standard rail are mounted on plate, I beam, channel or box sections.

AFR-3000 SEMI-FLEX RAIL / CROSS SECTION / EXPLODED VIEW / PARTS LIST

SEMI-FLEX RAIL can be bent inside or outside to a minimum radius of 15' (5 m) without permanent deformation. A splice plate is mounted at one end of each flex-rail section for connecting multiple sections of rail. A rack adjusting tool is supplied with every two (2) rails, for moving the rack on the rail. Available in 8' (2.37 m) lengths. Use at least four (4) attachments - vacuum cups or magnets - on each section of Semi-Flex Rail.

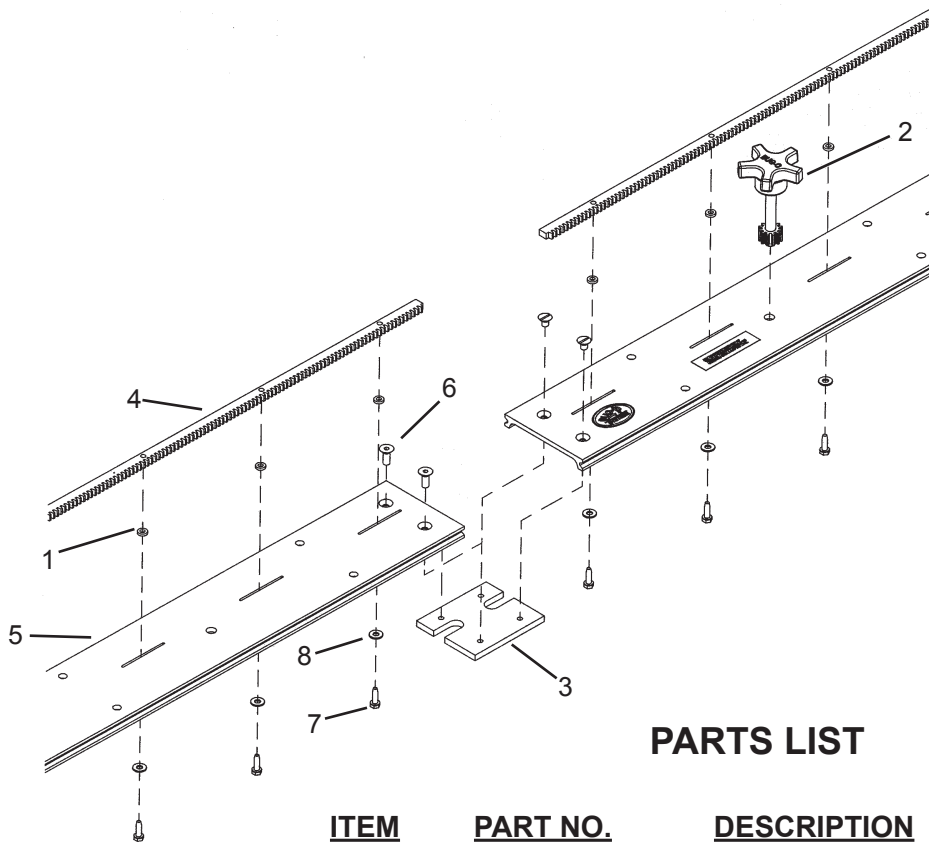
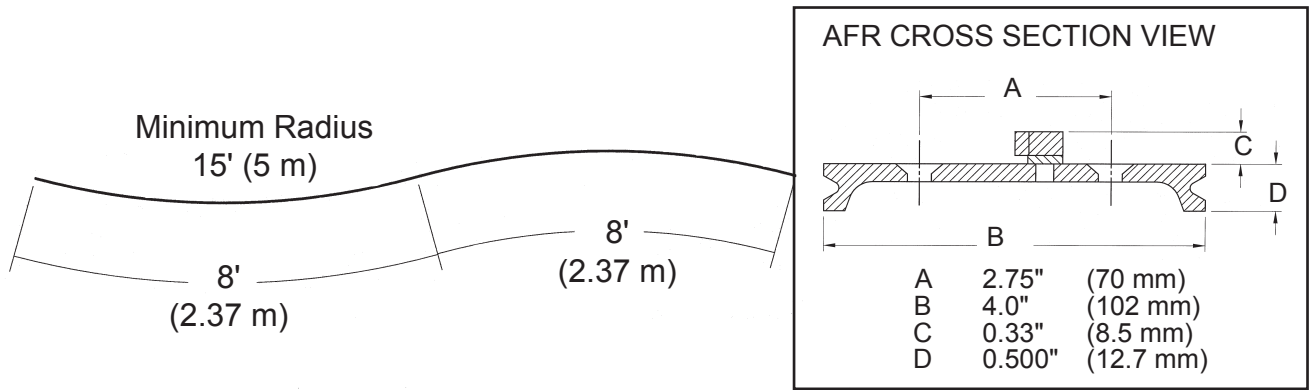

PARTS LIST

<u>ITEM</u>	<u>PART NO.</u>	<u>DESCRIPTION</u>	<u>QTY</u>
1	AFR-1015	Spacer Washer	16
2	AFR-2001	Rack Adjuster Tool	1
3	AFR-3002	Splice Plate	1
4	AFR-3006	Rack	1
5	AFR-3009	Extrusion, Punched	1
6	FAS-0955	Screw, Flt Hd Soc 1/4-20 x 1/2	4
7	FAS-1446-HW	S.T. Slit. Hx. #10-32 x 5/8	16
8	WAS-0230	#10 Washer	16

ARM-2010 / AFR-2010 ON/OFF MAGNET ASSEMBLY

STANDARD MAGNET ASSEMBLIES

MAGNET PLATE ASSEMBLIES mount ARR rail quickly and conveniently right on the work surface. Magnets cannot exert maximum pull on dirty material. Remove excessive paint, scale and rust from the area on which the magnets will be placed.

KEEP MAGNETS CLEAN before positioning, wipe off magnetic particles which adhere to the poles.

ARM-2010 & AFR-2010 - The Bug-O/ Mag-switch, Switchable On/Off Rare-Earth magnet assembly provides for quick rail positioning without fighting the magnet. The lighter weight, at just 1.7 lb. (0.77 kg), less than all other magnet assemblies, improves handling. 250 lbs (113.4 kg) holding capacity. ARM-2010 Fits standard ARR-rails and AFR-2010 Fits AFR Rails.

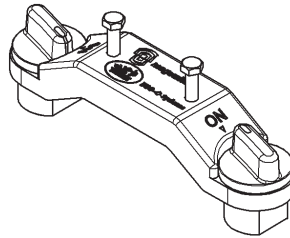

ARM-2010

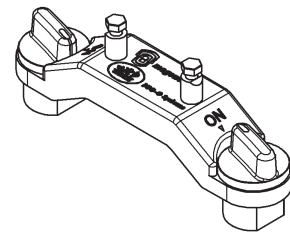

AFR-2010

ARR & AFR VACUUM ASSEMBLIES

**ARV-1085 VACUUM KIT
FOR ARR-1085 4' (1.18 MM)
RIGID RAIL**

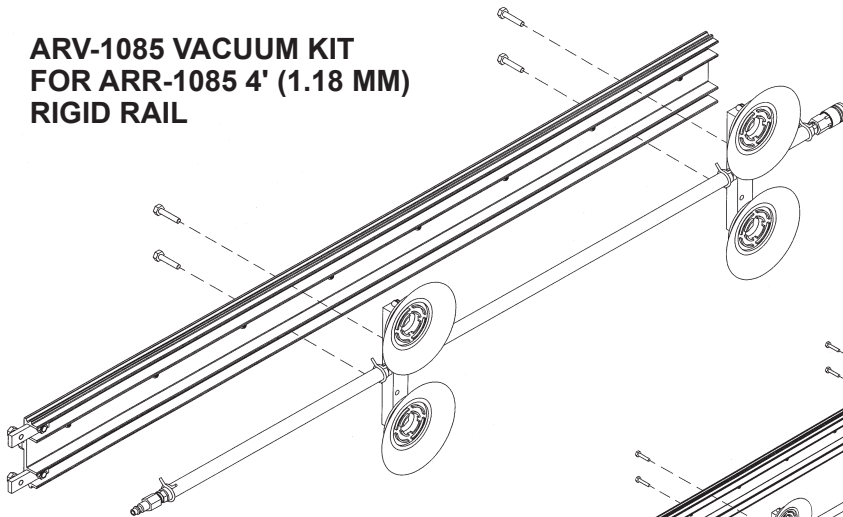

**ARV-1080 VACUUM KIT
FOR ARR-1080 8' (2.37 MM)
RIGID RAIL**

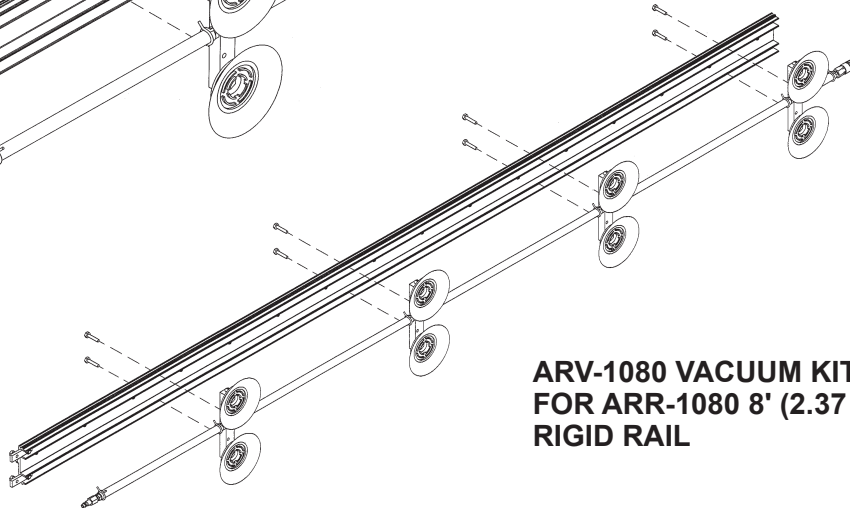

MPD-1065 RELEASABLE CARRIAGE / EXPLODED VIEW / PART LIST

Two carriages are available for the **Modular Drive System** when using BUG-O Aluminum Rigid and Semi-Flex Rails. Both carriages are made of a high-strength, lightweight aluminum alloy, with wheels that ride in opposed recessed rail grooves.

The MPD-1065 Releasable 12" (305 mm) Carriage can be placed anywhere on the track by using the knob located on the side of the carriage, which engages or disengages the wheels from the rail. The MPD-1055 18" (457 mm) Carriage provides an extended deck for mounting accessories, wire feeder, etc. The pinion from the drive unit engages the rack on the rail, providing positive drive in all positions. On each carriage, one set of wheels is adjustable to allow for smooth, accurate travel. All wheels contain permanently lubricated, sealed bearings and their steel components are plated to resist corrosion.

The MPD-1065 Releasable 12" Carriage has a carrying capacity of 100 lb (45 kg) and can be placed anywhere on the rail by using the knob located on the side of the carriage, which engages or disengages the wheels from the rail. Use with BUG-O Aluminum Rigid or Semi-Flex Rails.

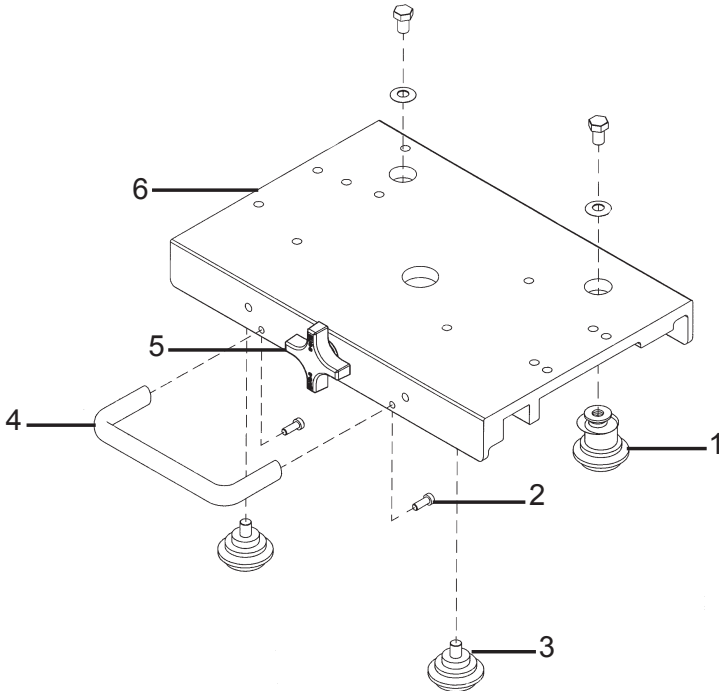

<u>ITEM</u>	<u>PART NO</u>	<u>DESCRIPTION</u>	<u>QTY</u>
1	BUG-1984	External Adj. Leg & Wheel Assembly	2
2	FAS-0545	Screw, Soc Hd Cap #10-32 x 1/2	2
3	MPD-1045	Fixed Leg & Wheel Assembly	2
4	MPD-1049	Handle, Black	1
5	MPD-1059	Knob Screw (Included w/ Carriage)	1
6	MPD-1066	Carriage	1

BRR-1180 BENT RIGID RAIL / CROSS SECTION / APPLICATION VIEW / PARTS LIST

BENT RIGID RAIL (BRR) is a rigid section of high quality alloy bent for circumferential applications. A machined gear rack is mounted on the rail, with which the pinion of the drive unit meshes, providing positive drive in all directions. The wheels of the carriage travel in opposed grooves at either side of the rail, securing the carriage to the rail. The rail can be ordered as a complete ring (BRR-1210-___) or as individual sections (BRR-1180). When ordering, specify the work diameter (inside or outside), method of mounting and if a complete ring is required. On larger diameters, rail can be "leapfrogged" around the vessel to reduce the quantity needed. Maximum section length is 80" (2 m).

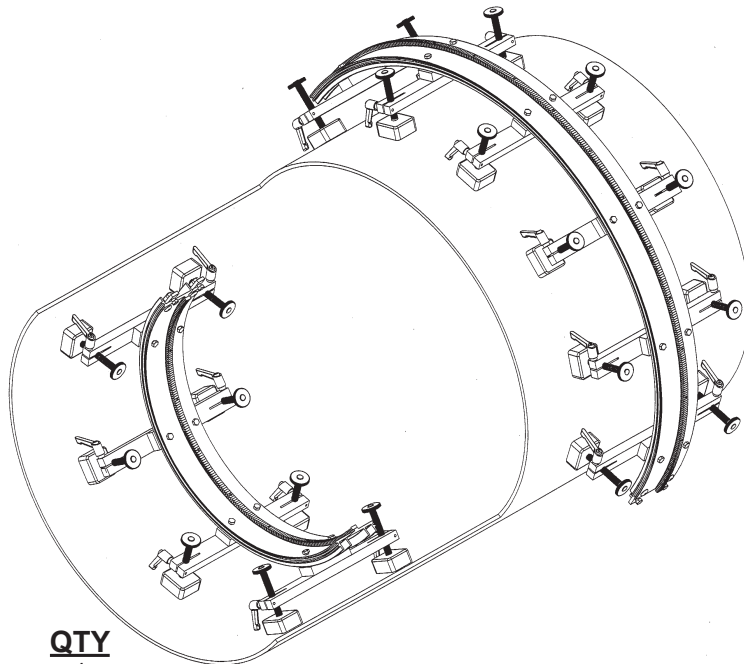
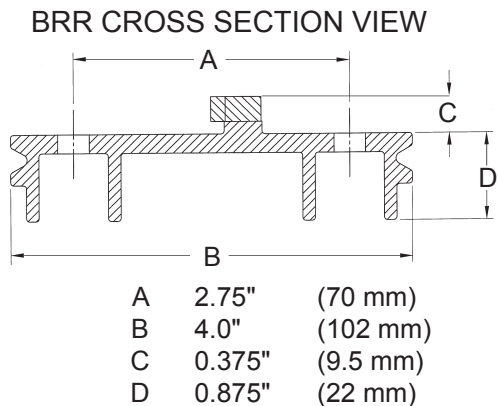

PARTS LIST

<u>PART NO.</u>	<u>DESCRIPTION</u>	<u>QTY</u>
ARR-1002	Rack	1
ARR-1027	Splicer Bar	2
ARR-1028	Carriage Bolt	2
ARR-1044-E	Rail Extrusion	1
FAS-0375	Hex Hd Cap Scr 5/16-18	2
FAS-1370	Hex Nut 5/16-18	2

Note: Adjustable magnet support legs (ARM-2480), shown above, are sold separately.

COMPLETE RING RAIL ASSEMBLIES

Ring Rails and Tube Size Ranges



PART NO.	Work Diameters		Ring Inside Diameter	
	INCHES	MM	INCHES	MM
(1) BRR-1210-20	9-16	230-400	20	500
(2) BRR-1210-27	16-23	410-580	27	680
(3) BRR-1210-34	23-30	590-760	34	860
(4) BRR-1210-41	30-37	770-940	41	1040
(5) BRR-1210-48	37-44	950-1120	48	1220

* Ring Rails do not include attachments.

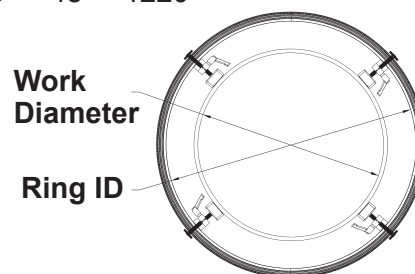

MAGNET ATTACHMENTS

A minimum of three (3) magnet plate or screw feet assemblies are required for each ring rail section.

Support Bar w/ Screw Feet ARM-2380

4.5" (114.3 mm) of Adj.
Also available as a
kit of three (3)
ARM-2390

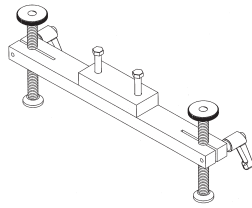

Support Bar w/ Magnets ARM-2480

3.5" (88.9 mm) of Adj.
Also available as a
kit of three (3)
ARM-2490

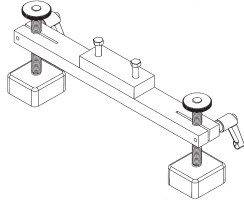

Support Bar w/ R.E On/Off Magnets ARM-2580

3.5" (88.9 mm) of Adj.
Also available as a
kit of three (3)
ARM-2590

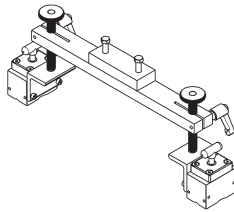

VACUUM SUPPORTS

Vacuum Supports may be used instead of magnets to mount the Ring Rail on non-magnetic work pieces. Each Vacuum Support System requires a Vacuum Pump Kit for operation.

ARV-1240-20 20" Dia. Vacuum Support System

ARV-1240-27 27" Dia. Vacuum Support System

ARV-1240-34 34" Dia. Vacuum Support System

ARV-1240-41 41" Dia. Vacuum Support System

ARV-1240-48 48" Dia. Vacuum Support System

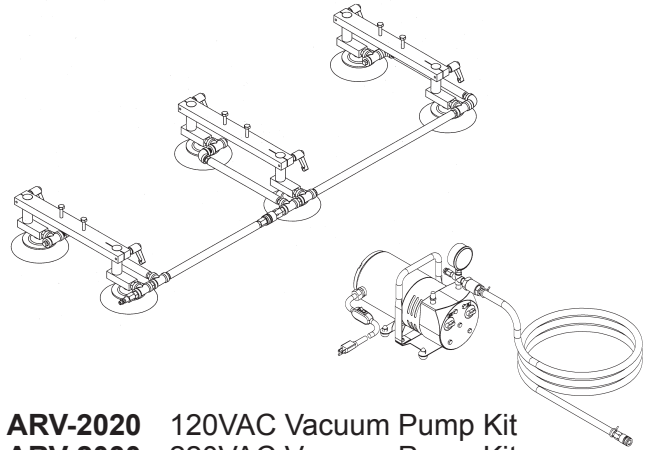

ARV-2020 120VAC Vacuum Pump Kit

ARV-2030 220VAC Vacuum Pump Kit

BUG-5910 TUBE CARRIAGE / EXPLODED VIEW / PARTS LIST

The Tube Carriage features a split carriage body for quick and easy placement on the rail. It has a carrying capacity of 100 lb (45 kg). The carriage also offers six (6) wheel positions for circumferential applications over a wide range of diameters. Use with BUG-O Aluminum Rigid, Semi-Flex or Bent Rigid Rails.

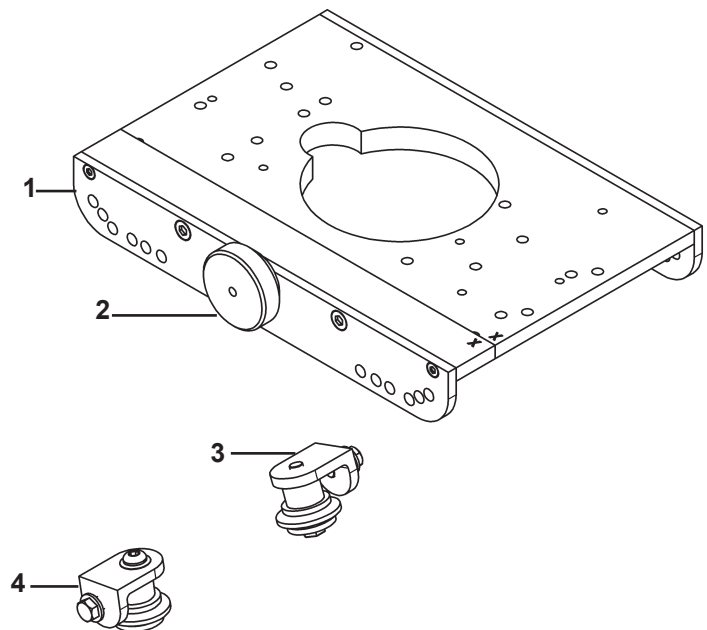

ITEM	PART NO	DESCRIPTION	QTY
1	BUG-5907	Skirt	2
2	BUG-5512	Knob	1
3	BUG-5918	Fixed Wheel Assembly	2
4	BUG-5920	Adj. Wheel Assembly	2

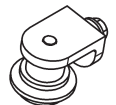

HI-FLEX RAIL / CROSS SECTION / EXPLODED VIEW / PARTS LIST

Hi-Flex Rail (FMD) & Corresponding Attachments

The FMD Flex Rail can flex from a straight to a 30" (760 mm) radius inside or outside. The rail is made from a tempered, wear resistant, stainless steel with a steel rack. It is designed for use with the FMD Hi-Flex Carriage and MDS Drive System. The rail comes in 57.7" (1.47 m) lengths and can be held in place with magnets or vacuum cups. An optional stiffener can be installed behind the rail for heavy duty, straight line applications.

FMD Hi-Flex Rail can flex inside or outside to a minimum radius of 30" (760 mm).

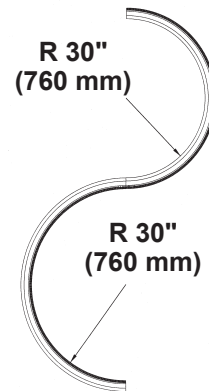

FMD-1050 HI-FLEX RAIL / CROSS SECTION / ASSEMBLED VIEW / PARTS LIST

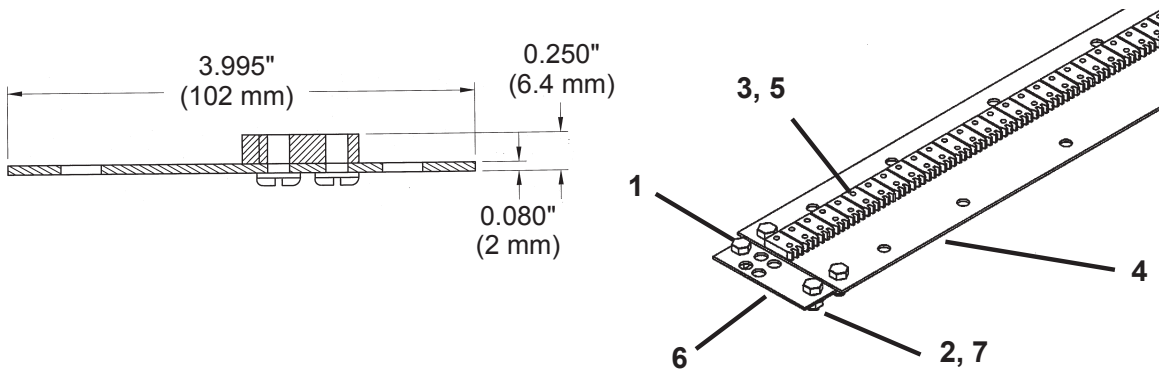

<u>ITEM</u>	<u>PART NO.</u>	<u>DESCRIPTION</u>	<u>QTY</u>
1	FAS-0376	Hex Hd Cap Screw 5/16-18 x 5/8 Long	4
2	FAS-1370	Hex Nut 5/16-18	4
3	FAS-1444	Phlp Pan Hd Scr #10-32 x 3/8 Long	196
4	FMD-1051	Track	1
5	FMD-1052	Rack Section, 3 Teeth	98
6	FMD-1053	Flex-Rail Splice Plate	1
7	WAS-0250	5/16 SAE Washer	4

FMD-2170 Hi-Flex Rail
with R.E. On/Off Magnets

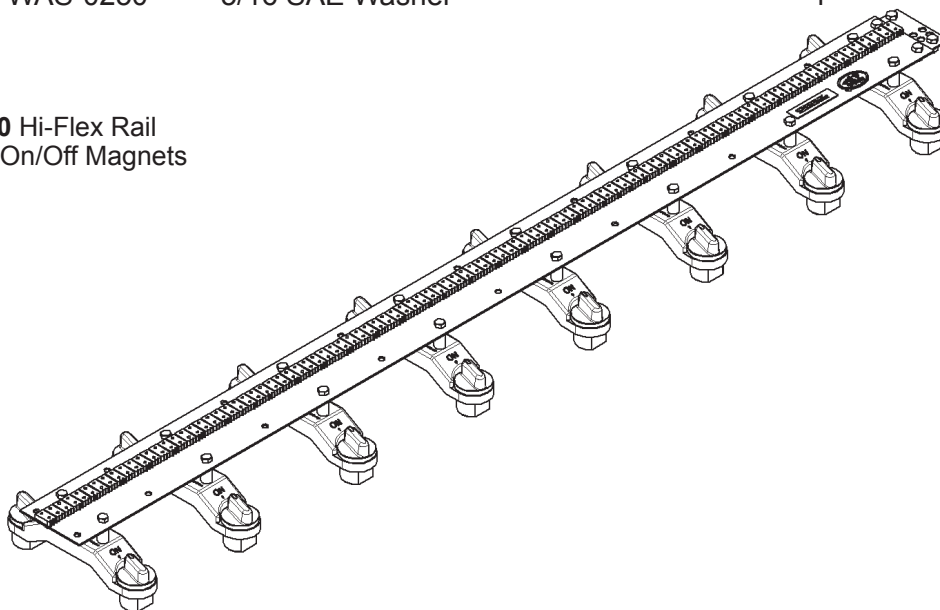

FMD-2010 R.E. ON/OFF MAGNET ASSEMBLY

STANDARD MAGNET ASSEMBLIES

MAGNET PLATE ASSEMBLIES mount ARR rail quickly and conveniently right on the work surface. Magnets cannot exert maximum pull on dirty material. Remove excessive paint, scale and rust from the area on which the magnets will be placed.

KEEP MAGNETS CLEAN before positioning, wipe off magnetic particles which adhere to the poles.

FMD-2010 - The New, Bug-O/Mag-switch, Switchable On/Off Rare-Earth magnet assembly provides for quick rail positioning without fighting the magnet. The lighter weight, at just 1.7 lb. (.77 kg), less than all other magnet assemblies, improves handling. 250 lb (113.4 kg) holding capacity. Fits standard FMD-rails.

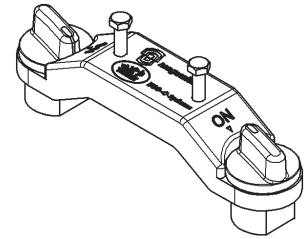

FMD-2010

FMD-1220 / FMD-1230 HI-FLEX VACUUM SUPPORTS AND VACUUM PUMP

FMD-1220 Vacuum Support for (1) FMD-1050*

FMD-1230 Vacuum Support for additional FMD-1050*

*FMD-1050 rail sold separately.

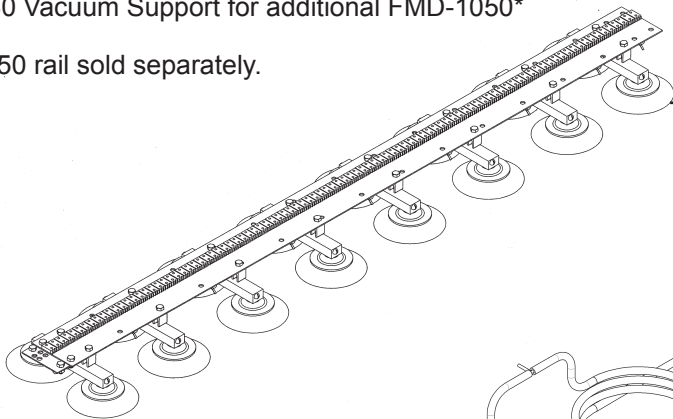

FMD-1036

VAC Support Bar For Hi-Flex Rail.

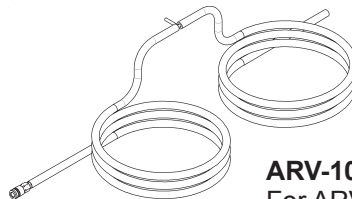

ARV-1060 Leap Frog Kit

For ARV-1080 & ARV-1085.

Used to reposition rail without losing vacuum.

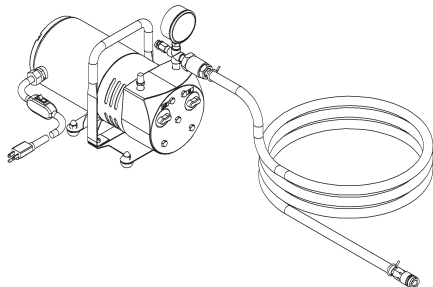

ARV-2020 120VAC/50-60 Hz/1Ph

ARV-2030 240VAC/50-60 Hz/1Ph

The ARV-2020 (ARV-2030) Vacuum Pump Kit is recommended for use with a maximum of four (4) pieces of rail, or sixteen (16) vacuum bars.

FMD-1105 12" HI-FLEX RAIL CARRIAGE / EXPLODED VIEW

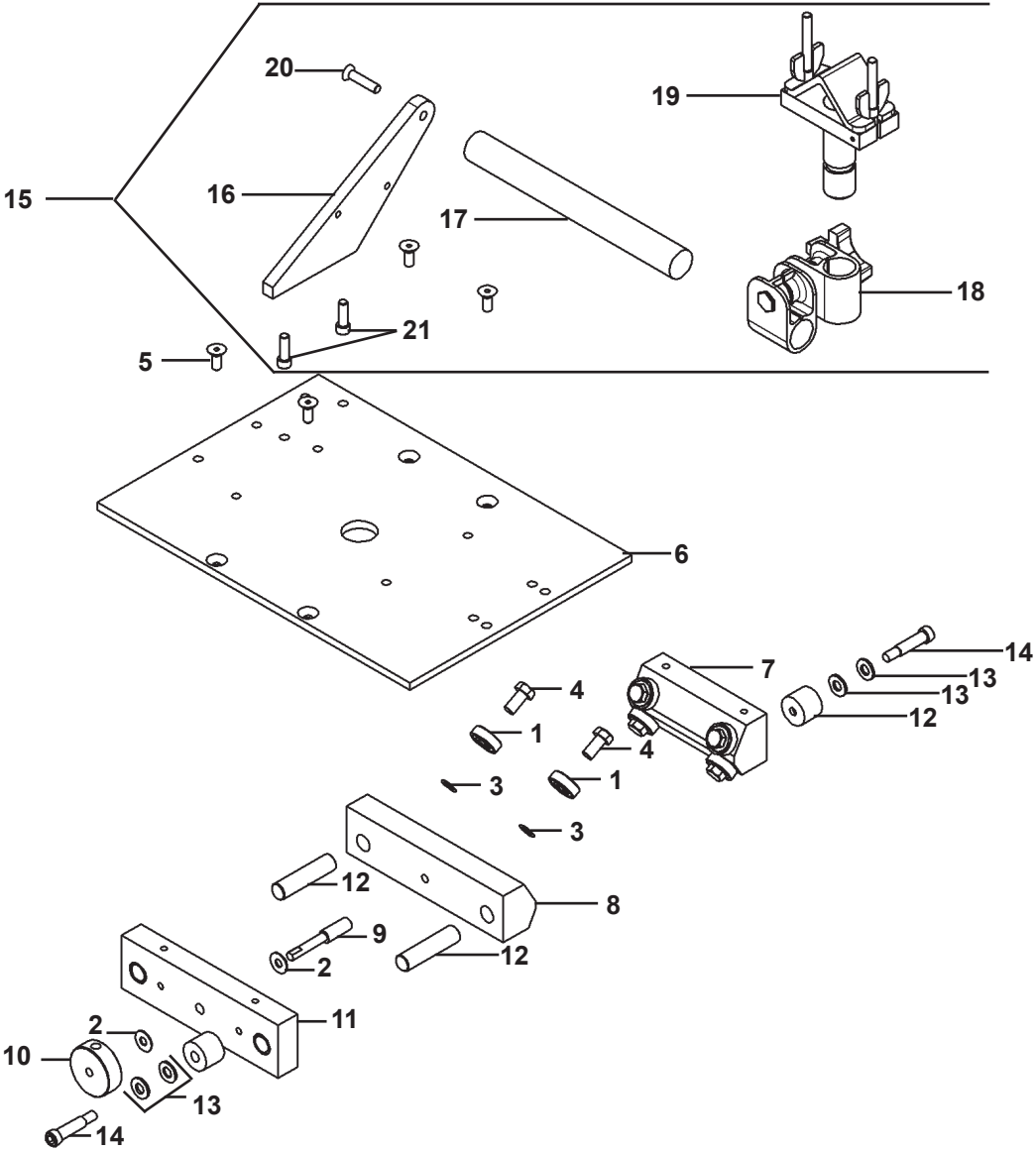

FMD-1105 12" HI-FLEX RAIL CARRIAGE / PARTS LIST

<u>ITEM</u>	<u>PART NO.</u>	<u>DESCRIPTION</u>	<u>QTY</u>
1	BUG-2012	Bearing	8
2	BUG-2848	Cam Bearing	2
3	CON-1029	Washer 5/16 x .015	8
4	FAS-0386	Hex Hd Cap Scr 5/16-24 x 5/8"	8
5	FAS-0959	Flt Hd Soc Scr 1/4-20 x 5/8"	4
6	FMD-1026	Carriage Cover	1
7	FMD-1068	Fixed Wheel Mounting Block	1
8	FMD-1069	Adj. Wheel Mounting Block	1
9	FMD-1071	Threaded Shaft	1
10	FMD-1072	Knob & 1/4-20 x 1/4 Set Screw	1
11	FMD-1081	Bearing Block	1
12	FMD-1083	Dowel Pin 1/2" x 2" Long	2
13	BUG-2841	Washer 5/8" O.D. x 5/16" I.D. Teflon	4
14	FAS-0659	Soc Hd Shr Scr 5/16-18 x 1"	2
15	MPD-1035	Handle w/ Cable Anchor (includes items 16-21)	1
16	MPD-1044	Mounting Angle	1
17	MPD-1047	Post for Handle	1
18	CON-1020	Swivel Clamp Assembly	1
19	BUG-2708	Clamp	1
20	FAS-0959	1/4-20 X 1" Flat Hd Socket	1
21	FAS-0557	Soc Hd Cap 1/4-20 x 3/4	2

VACUUM PUMP / EXPLODED VIEW

ARV-2020 VACUUM PUMP KIT, 120 VAC 60HZ/1PH

ARV-2030 VACUUM PUMP KIT, 240 VAC 50HZ/1PH

The **VACUUM PUMP KITS** are 1/6 HP units that provide 15" (381 mm) Hg on continuous duty. The ARV-2020/2030 Pump will support 30 vacuum cups.

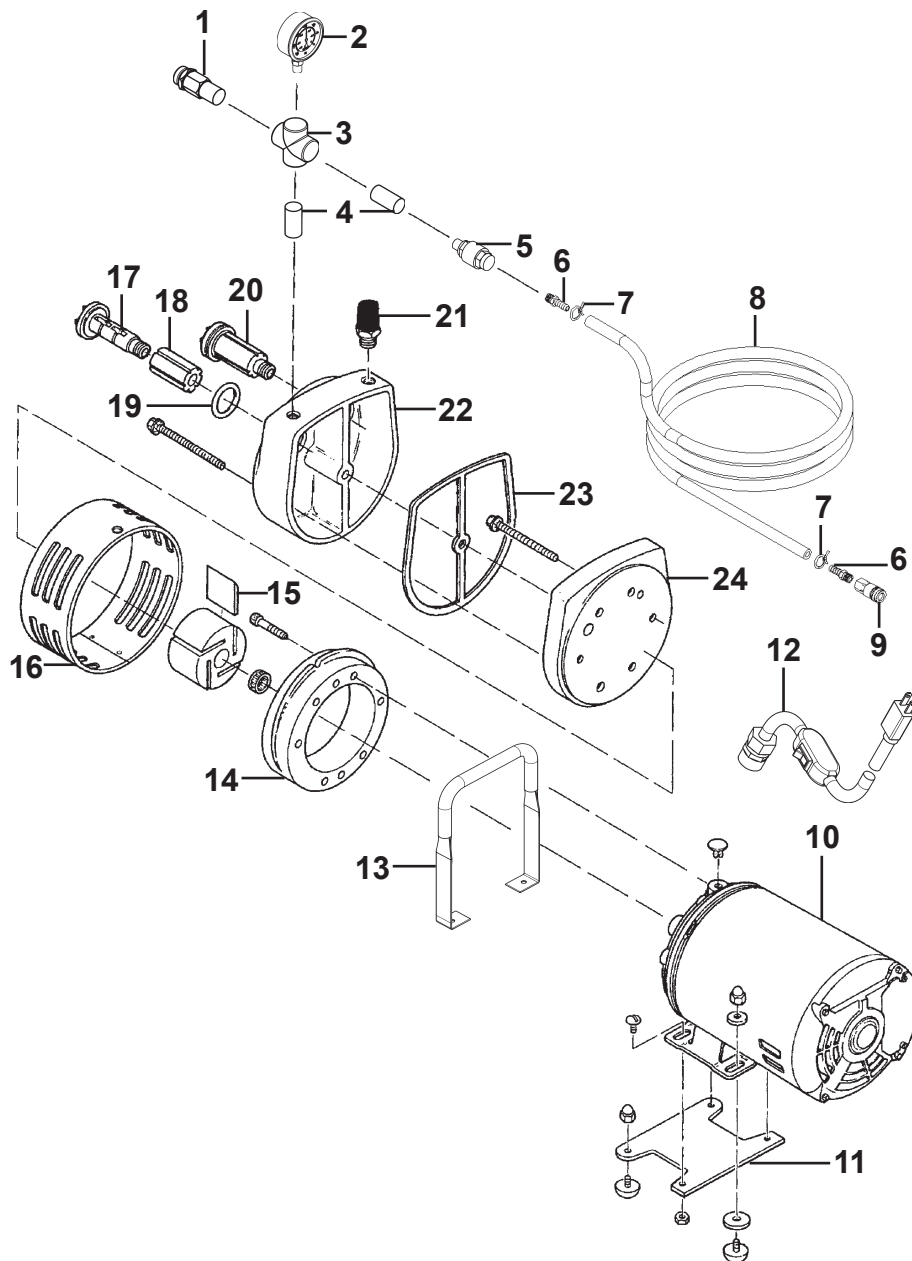

VACUUM PUMP / PARTS LIST

<u>ITEM</u>	<u>PART NO.</u>	<u>DESCRIPTION</u>	<u>QTY</u>
1	ARV-2017	1/4" Brass Vacuum Relief Valve	1
2	ARV-2014	Vacuum Gage	1
3	ARV-2018	1/4" NPT Union Cross, Female	1
4	ARV-2012	1/4" NPT Nipple	2
5	ARV-2016	1/4" NPT Brass Check Valve, F	1
6	ARV-1107	3/8" Hose Barb x 1/4" NPT-M	2
7	ARV-1005	11/16" x .112 Thk Clamp	2
8	ARV-1004-P	Hose 3/8" ID x 11/16" OD	1
9	ARV-1012	Female Quick Connector	1
10	ARV-2019	Pump	1
11	ARV-1999	Foot Support w/ Fasteners	1
12	ARV-2021	120 VAC Power Cord w/ Switch	1
*		†240 VAC Replacement Power Components	
13	ARV-2013	Handle	1
14	ARV-2011	Body	1
15	ARV-2010	Vane	4
16	ARV-2009	Shroud	1
17	ARV-2003	End Cap	2
18	ARV-2004	Felt	2
19	ARV-2005	O-ring	2
20	ARV-2002	End Cap Assembly (Includes parts 17-19)	2
21	ARV-2001	Filter/Muffler	1
22	ARV-2006	Muffler Box	1
23	ARV-2007	Gasket	1
24	ARV-2008	End Plate	1
†240 VAC requires the items below			
*	BUG-9233	Label, 240 VAC	1
*	BUG-9593	240 VAC Twist Plug	1
*	BUG-9594	240 VAC Connector Body	1
*	ARV-2021	120 VAC Power Cord w/ Switch	1

*Not Shown

ARV-1036 VACUUM SUPPORT BAR FOR ARR, AFR AND BRR RAILS

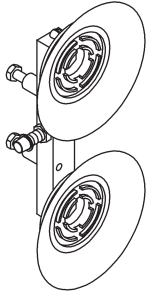

VACUUM CUPS are used for mounting the rail to the workpiece when magnet bars will not hold. EXAMPLE: Stainless steel or nonferrous surfaces. The surface must be smooth and nonporous.

Each vacuum bar is fitted with two (2) cups and will exert a maximum pull of 100 lbs. (45 kg).

ARV-1036 VACUUM SUPPORT BAR / EXPLODED VIEW / PARTS LIST

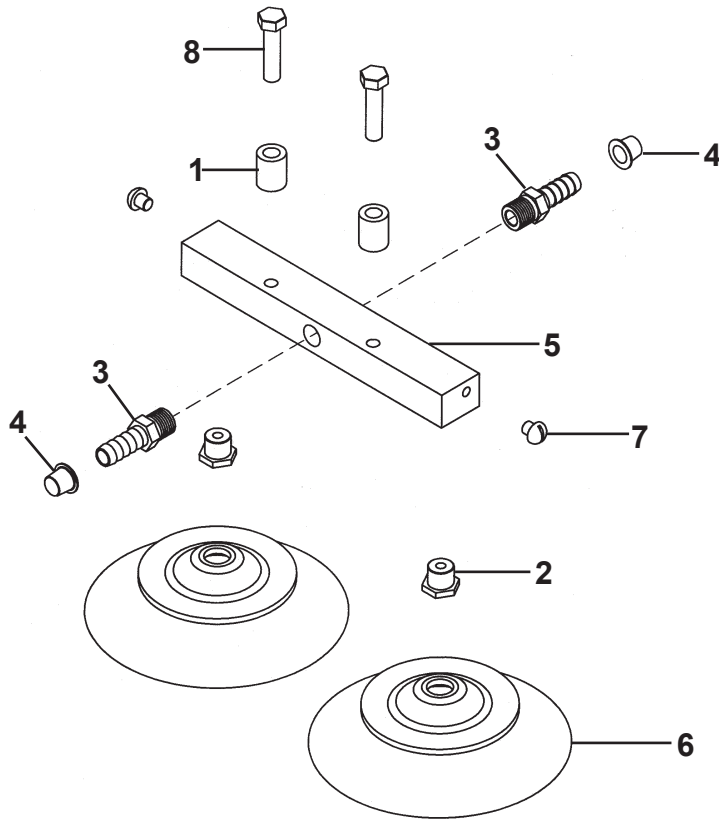

<u>ITEM</u>	<u>PART NO.</u>	<u>DESCRIPTION</u>	<u>QTY</u>
1	ARR-9008	Spacer Tube	2
2	ARV-1034	Choke Nipple	2
3	ARV-1107	3/8 Hose Barb x 1/4 NPT-M	2
4	ARV-1109	Protective Cap	2
5	ARV-1111	Support Bar	1
6	ARV-1116	Vacuum Cup (Silicone)	2
7	FAS-0252	Rnd Hd Scr 1/4-20 x 1/4	2
8	FAS-2372	Hex Hd Cap Scr 5/16-18 x 1-1/4	2

NOTE: Keep flame or arc at least 4" (101 mm) away from vacuum cups. Vacuum cups can be used on preheated material to 600° F (315° C). Each vacuum cup exerts a maximum pull of 50 lbs. (22.6 kg).

ARV-1036 Vacuum Support Bar is used on all ARR, AFR and BRR rails.

FMD-1036 VACUUM SUPPORT BAR FOR FMD RAIL / EXPLODED VIEW / PARTS LIST

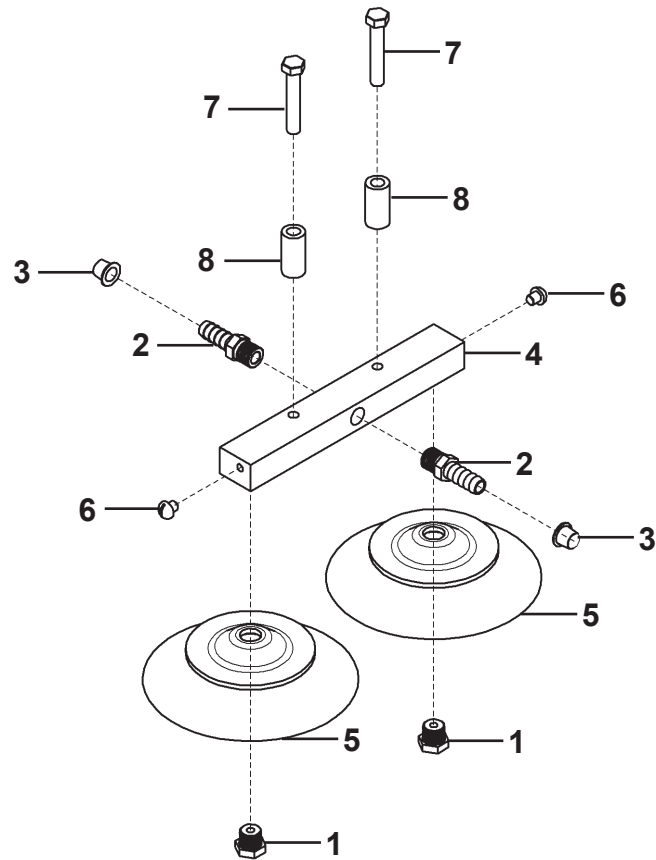

<u>ITEM</u>	<u>PART NO</u>	<u>DESCRIPTION</u>	<u>QTY</u>
1	ARV-1034	Choke Nipple	2
2	ARV-1107	3/8" Hose Barb	2
3	ARV-1109	Protective Cap	2
4	ARV-1111	Support Bar	1
5	ARV-1116	Vacuum Cup	2
6	FAS-0252	Rnd Hd Scr 1/4-20 x 1/4"	2
7	FAS-2374	Hex Hd Cap Scr 5/16-18 x 1-3/4"	2
8	FMD-2014	Flex Rail Spacer Tube	2

ARC GOUGING MODULAR DRIVE TROUBLESHOOTING GUIDE

BUG-O's Modular Drive System is a system that permits mixing and matching of components to build a customized solution to specific applications. This provides the owner the ability to replace and remove individual components while troubleshooting, which significantly reduces time and effort required to troubleshoot the system. The recommended troubleshooting procedure is as follows:

BUG-O's ARC Gouging MODULAR DRIVE SYSTEM is a marriage of BUG-O Systems Drive and Rail System with ARCAIR® AUTOMATIC GOUGING SYSTEM. The only electrical / control connection between the BUG-O and the Arcair® Control Box is the MODULE POWER CORD to the 120VAC Power Outlet on N7500 Control Box.

If problems do occur, it is imperative that the two systems are isolated and tested separately to confirm that each unit is operating properly. Then, after confirming each system is functioning properly the only remaining issue is the connection between the two systems.

- 1) Verify that there are no loose electrical or mechanical connections.
- 2) Verify that the Gouging power sources are properly grounded and it's ground clamp is attached to the work piece.
- 3) Ensure the High Frequency Warnings in the front of this IPM are not being violated.
- 4) When possible, swap out each component in the system one at a time with a known good component. For example, replace the Control Module on a defective machine with the Control Module from a working machine. Often this will pinpoint the defective component quickly.
- 5) Remove all attached components. All attached components are removed to limit the number of components affecting the operation and complexity of the system. Assemble a base system composed of a Control Module and a Master Drive. Test the base system. If the base system does not work, troubleshoot the base system to a circuit board level using the **Base System Test Procedure**. If possible, test the Control Module by swapping it with a known good module.
- 6) Finish installing the components one at a time. Test the system after each installation in order to identify the problem component(s).

ARC GOUGING MODULAR DRIVE TROUBLESHOOTING GUIDE, (CONT'D.)

PROBLEM	POSSIBLE CAUSE	TEST	BASE SYSTEM TEST PROCEDURE / REMEDY
Speed display is not lit and tractor does not run.	Power switch is OFF.	1A	Turn ON the main ON/OFF switch located in the power entry module. (see Figure 1)
	No power to machine.	1B	Verify the power cord is OK and the correct voltage exists at the outlet.
	Blown fuse.	1C	Unplug the power cord. Check the machine's power input fuse(s). The fuse(s) is located in the power entry module and is accessible without opening the case.
	Faulty accessory attached to the master drive accessory port.	1D	<p>Remove any accessory plugged into the master drive accessory port (see figure 2). Plug in the power cord and turn on the main power.</p> <p>a) If the speed display does not light, proceed with test 1E</p> <p>b) If the speed display lights, install the connector cover on the accessory port. NOTE: FAILURE TO INSTALL THE CONNECTOR COVER ON THE ACCESSORY PORT AFTER COMPLETING THIS TEST MAY CAUSE SERIOUS INJURY FROM ACCIDENTAL ELECTRICAL SHOCK.</p> <p>Set the tractor for continuous forward motion at full speed. If the control module has any type of motion enable switch, turn it to enable.</p> <p>1) If the tractor does not work properly, proceed with step 2A.</p> <p>2) If the tractor operates correctly, the accessory removed from the accessory port is defective.</p>
	Faulty power entry module.	1E	<p>Remove the connector cover or any attached accessory from the master drive accessory port (see Figure 2). Verify the power line voltage is on the two outer pins of the three pin connector (see Figure 2). The center pin is chassis ground.</p> <p>NOTE: INSTALL THE CONNECTOR COVER ON THE ACCESSORY PORT AFTER COMPLETING THIS TEST. FAILURE TO INSTALL THE COVER MAY CAUSE SERIOUS INJURY FROM ACCIDENTAL ELECTRICAL SHOCK.</p> <p>If the voltage is not present, rerun tests 1A, 1B, 1C, 1D and 1E. A second failed 1E test indicates bad internal AC wiring or a defective power entry module. Open the master drive case (see Figure 3). Examine the AC wiring and rewire at fault or replace the power entry module assembly. NOTE: The replacement power entry module is provided with the accessory port's three pin AC connector prewired.</p>

ARC GOUGING MODULAR DRIVE TROUBLESHOOTING GUIDE, (CONT'D.)

PROBLEM	POSSIBLE CAUSE	TEST	BASE SYSTEM TEST PROCEDURE / REMEDY
	Defective RFI	1F	Disconnect the two RFI filter output wires (see Fig. 1). Turn ON the main power. Verify the power line exists on the two output wires. Reconnect the wires. Replace the RFI filter if the power line voltage is not present
	Bad Power Supply	1G	Turn ON main power. The Green LED's L1 and L2 (see Fig 1) will light if the power supply is OK. If the LED's are OFF, unplug the power supply output connector (see Fig. 1). The connector wiring is: White & Red is +15 V DC (+/- 2V). White & Black is DC ground. White & Orange is -15 V DC (+/- 2V). Measure voltages at the connector. a) A bad voltage indicates a defective power supply. Replace the power supply. b) Correct voltages indicate the power supply is OK, however, there is a short in the equipment. Plug in the power supply output connector. Perform test 1H.
	Short Circuit	1H	The Green LED's L1 and L2 will light when the short is removed. Unplug the following and monitor the LED's to see if the short is removed: 1) The Control Module, 2) The speed card input power connector (see Fig. 1). 3) all connectors attached to the interconnect card (see Fig. 1), except the connector for the supply. If L1 and/or L2 never turn ON, the interconnect card is bad. Replace the board.
No tractor speed control and display is LIT.	Operator Error	2A	Set the MODE switch to CONTINUOUS and the CARRIAGE TRAVEL switch to STOP. Turn the SPEED CONTROL clockwise. Proceed to step 2B if the display does not increase. If the display does not increase, then turn the CARRIAGE TRAVEL switch to FORWARD. Open the master drive case (Fig. 3) and proceed to step 2C. If the tractor does not move forward.
	Bad DC Power	2B	Open the masters drive case (fig. 3). Unplug the power supply output connector (see Fig. 1). The connector wiring White & Red is +15 V DC (+/- 2V). White & Black is DC ground. White & Orange is -15 V DC (+/- 2V). Measure the voltages at the connector. A missing or bad voltage indicates a bad power supply. Replace the power supply.
	Faulty Motor Wiring	2C	Check the wires from the speed card to the motor for faults. Rewire if needed.
	Faulty Motor	2D	Disconnect the motor leads. Apply 2 to 8 volts DC across the motor leads. Verify that the motor spins.

ARC GOUGING MODULAR DRIVE TROUBLESHOOTING GUIDE, (CONT'D.)

PROBLEM	POSSIBLE CAUSE	TEST	BASE SYSTEM TEST PROCEDURE / REMEDY
No tractor speed control and display is lit.	Faulty Control module, speed card, or motor.	2F	<p>Install one voltmeter lead on TP4 and the other lead on TP5. Turn on the main power. Set the control module for continuous forward tractor motion. If the control module has any type of motion enable switch, turn it to enable. Rotate the tractor speed control knob while observing the voltmeter output. It is possible to vary this voltage between 0 and 8 volts DC using a good control module.</p> <ol style="list-style-type: none"> a) if the voltage does not vary, replace the control module card. b) If the voltage does not vary, turn the machine OFF and then ON using the main power switch. Observe LED L5. L5 should light for a moment or two during power-up while safety circuits hold the tractor OFF until full power is reached. L5 should turn OFF indicating power is reached. L5 should turn OFF indicating power has been applied to the motor and motion should start. <ol style="list-style-type: none"> 1) If the L5 never lights, replace the speed card. 2) If the L5 turns ON, turns OFF, and then turns ON, check for shorted motor connections. If none are found, replace the speed card. 3) If the L5 turns ON and stays ON, check that the control module is set up as defined above and retest 2T. A second failure indicates a bad speed card. Replace Speed Card. 4) If L5 turns ON and then OFF and the motor doesn't start running, thru the tractor speed up. If the motor does not begin to turn, check the motor speed card wiring for faults and repair as needed. If the motor still fails to turn, replace the speed card.
Tractor Moves a short distance and then stops	High Frequency Interference	3A 3B 3C	<p>Turn OFF ARC GOUGING unit. The unit should operate normally.</p> <p>Verify load on the carriage does not exceed the factory rating.</p> <p>Remove unit from track and set the controls to forward tractor motion. If the pinion motion stops after a short time or a check shows that the weight placed on the machine is not excessive, then the problem is most likely brake related. Return machine for repair.</p>

ARC GOUGING MODULAR DRIVE TROUBLESHOOTING GUIDE, (CONT'D.)

The Modular Drive System is equipped with internal fault diagnostic LEDs and test Points 10 Speed troubleshooting as shown below. Test point evaluation should be performed by a qualified technician using a volt meter. If a qualified technician is not available, return the unit to the factory for repair. Always unplug the power cord before opening the case.

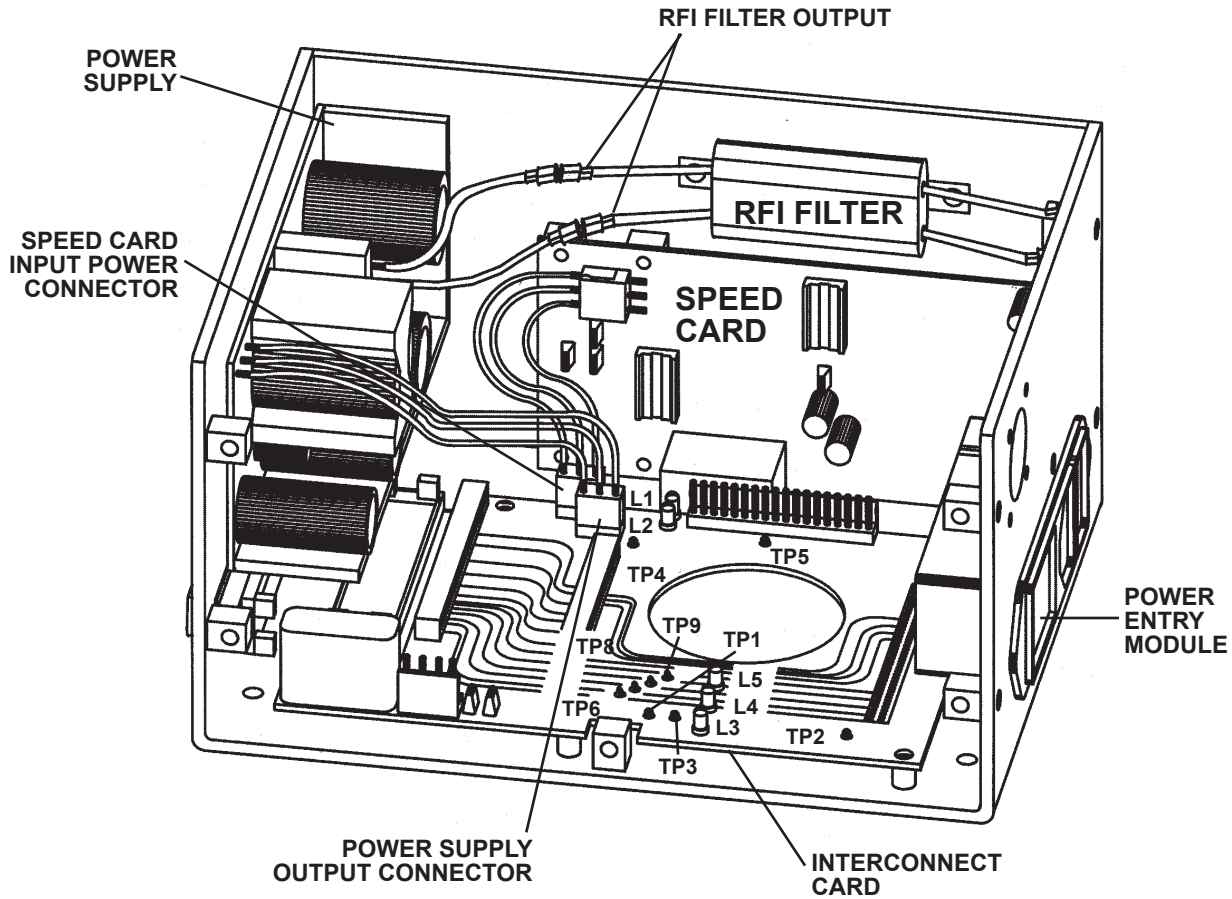

Figure 1. Troubleshooting Test Points

TEST POINTS

TP1	-15V
TP2	GND
TP3	+15V
TP4	Tractor + Speed Command
TP5	Tractor - Speed Command
TP6	Weaver + Speed Command
TP7	Weaver - Speed Command
TP8	Height + Speed Command
TP9	Height - Speed Command

L1	-15v
L2	+15V
L3	Height Off
L4	Weaver Off
L5	Tractor Off

ARC GOUGING MODULAR DRIVE TROUBLESHOOTING GUIDE, (CONT'D.)

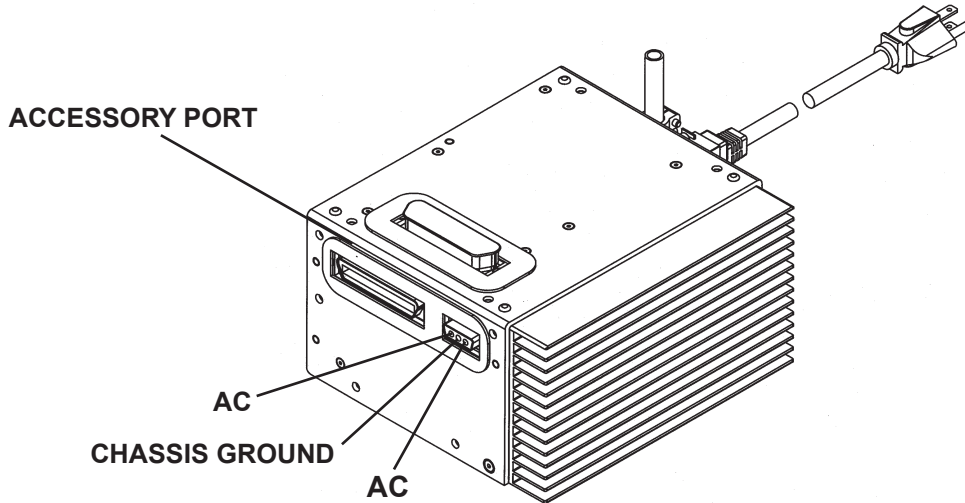
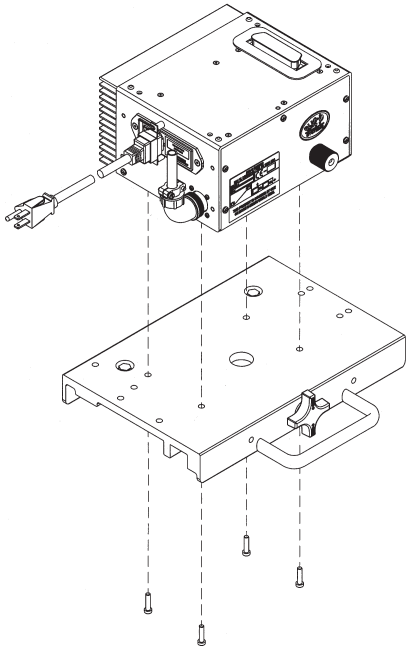

Figure 2. Master Drive Accessory Port

Figure 3. Procedure for Opening the Master Drive Case:

1. Unplug the power cord.



2. Unbolt the Master Drive from the carriage.

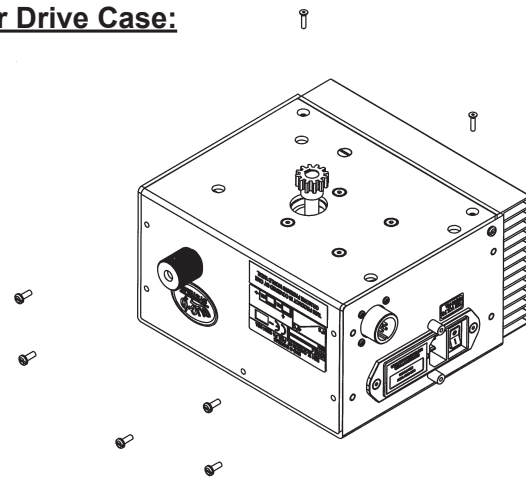

3. Remove ONLY the seven screws as shown.

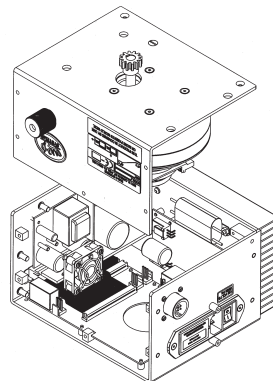

4. Open the case.

CAUTION: Unplug the power cord before opening or closing the case or serious injury may result.

NOTES:

MASTER DRIVE WIRING DIAGRAM MDP-1000/ MDP-1002/ MDP-1004

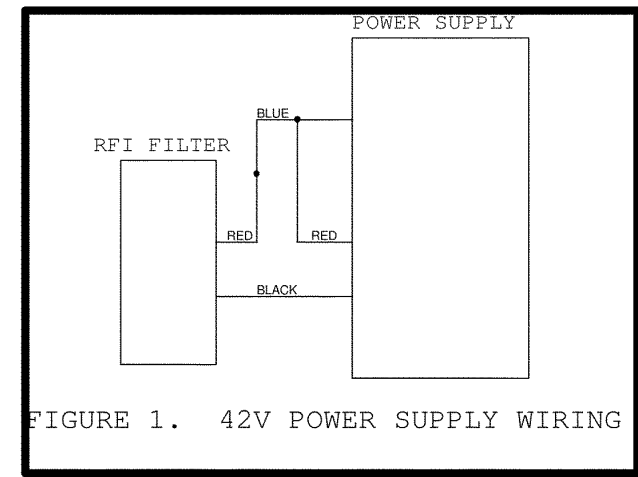
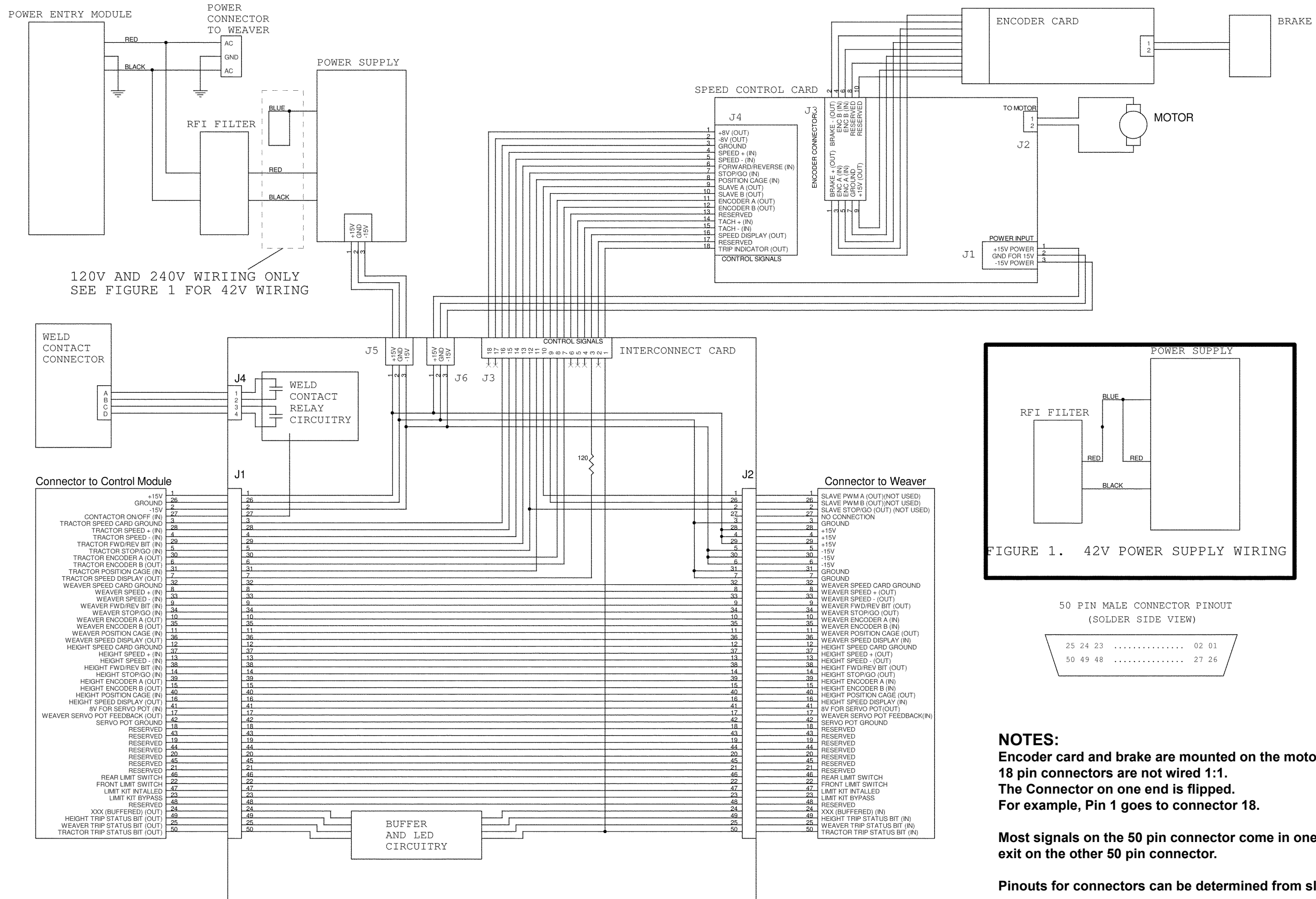
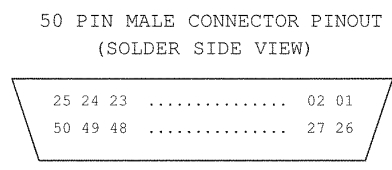

FIGURE 1. 42V POWER SUPPLY WIRING



NOTES:
Encoder card and brake are mounted on the motor.
18 pin connectors are not wired 1:1.
The Connector on one end is flipped.
For example, Pin 1 goes to connector 18.

Most signals on the 50 pin connector come in one 50 pin connector and exit on the other 50 pin connector.

Pinouts for connectors can be determined from slik-screen.

WARRANTY

Limited 3-Year Warranty*

Model _____
Serial No. _____
Date Purchased: _____
Where Purchased: _____

For a period ending one (1) year from the date of invoice, Manufacturer warrants that any new machine or part is free from defects in materials and workmanship and Manufacturer agrees to repair or replace at its option, any defective part or machine. HOWEVER, if the invoiced customer registers the Product Warranty by returning the Warranty Registration Card supplied with the product within 90 days of the invoice date, or by registering on-line at www.bugo.com, Manufacturer will extend the warranty period an additional two (2) years which will provide three (3) total years from the date of original invoice to customer. This warranty does not apply to machines which, after Manufacturer's inspection are determined by Manufacturer to have been damaged due to neglect, abuse, overloading, accident or improper usage. All shipping and handling charges will be paid by the customer.

The foregoing express warranty is exclusive and Manufacturer makes no representation or warranty (either express or implied) other than as set forth expressly in the preceding sentence. Specifically, Manufacturer makes no express or implied warranty of merchantability or fitness for any particular purpose with respect to any goods. Manufacturer shall not be subject to any other obligations or liabilities whatsoever with respect to machines or parts furnished by Manufacturer.

Manufacturer shall not in any event be liable to Distributor or any customer for any loss of profits, incidental or consequential damages or special damages of any kind. Distributor's or customer's sole and exclusive remedy against Manufacturer for any breach of warranty, negligence, strict liability or any other claim relating to goods delivered pursuant hereto shall be for repair or replacement (at Manufacturer's option) of the machines or parts affected by such breach.

Distributor's Warranty:

In no event shall Manufacturer be liable to Distributor or to any customer thereof for any warranties, representations or promises, express or implied, extended by Distributor without the advance written consent of Manufacturer, including but not limited to any and all warranties of merchantability or fitness for a particular purpose and all warranties, representations or promises which exceed or are different from the express limited warranty set forth above. Distributor agrees to indemnify and hold Manufacturer harmless from any claim by a customer based upon any express or implied warranty by Distributor which exceeds or differs from Manufacturer's express limited warranty set forth above.

HOW TO OBTAIN SERVICE:

If you think this machine is not operating properly, re-read the instruction manual carefully, then call your Authorized BUG-O dealer/distributor. If they cannot give you the necessary service, write or phone us to tell us exactly what difficulty you have experienced. BE SURE to mention the MODEL and SERIAL numbers.

*Bug-O System's warranty applies to Bug-O components only. Where other brands of power sources, wire feeders or sub components are a part of Bug-O Equipment, please refer to that specific Manufacturer's manual for warranty specifications on their components.